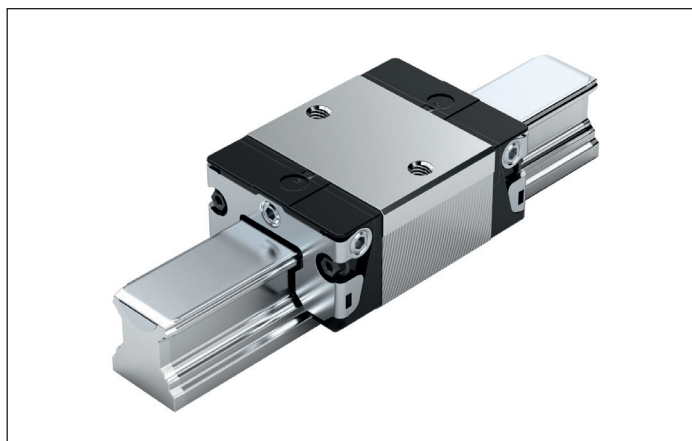

## SKS – slimline short standard height R1666 ... 2.

**Dynamic characteristics**Travel speed:  $v_{\max} = 5 \text{ m/s}$ Acceleration:  $a_{\max} = 500 \text{ m/s}^2$ (If  $F_{\text{comb}} > 2.8 \cdot F_{\text{pr}}$ :  $a_{\max} = 50 \text{ m/s}^2$ )**Note on lubrication**

▶ Pre-lubricated

**Note**

For all SNS/SNO ball guide rails.

**Options and part numbers**

Size	Ball runner block with size	Preload class		Accuracy class		Seal with ball runner blocks					
		C0	C1	N	H	without ball chain			with ball chain		
						SS	LS	DS	SS	LS	DS
15	R1666 1	9		4	3	20	21	–	22	23	–
			1	4	3	20	21	–	22	23	–
20	R1666 8	9		4	3	20	21	–	22	23	–
			1	4	3	20	21	2Z	22	23	2Y
25	R1666 2	9		4	3	20	21	–	22	23	–
			1	4	3	20	21	2Z	22	23	2Y
30	R1666 7	9		4	3	20	21	–	22	23	–
			1	4	3	20	21	2Z	22	23	2Y
35	R1666 3	9		4	3	20	21	–	22	23	–
			1	4	3	20	21	2Z	22	23	2Y
e.g.	R1666 7		1		3	20					

**Order example**

Options:

- ▶ SKS ball runner block
- ▶ Size 30
- ▶ Preload class C1
- ▶ Accuracy class H
- ▶ With standard seal, without ball chain

Part number:

R1666 713 20

**Preload classes**C0 = Without preload (clearance)  
C1 = Moderate preload**Seals**SS = standard seal  
LS = low-friction seal  
DS = double-lipped seal**Key**Gray digits  
= No preferred variant/  
combination  
(Some delivery times may  
be longer)

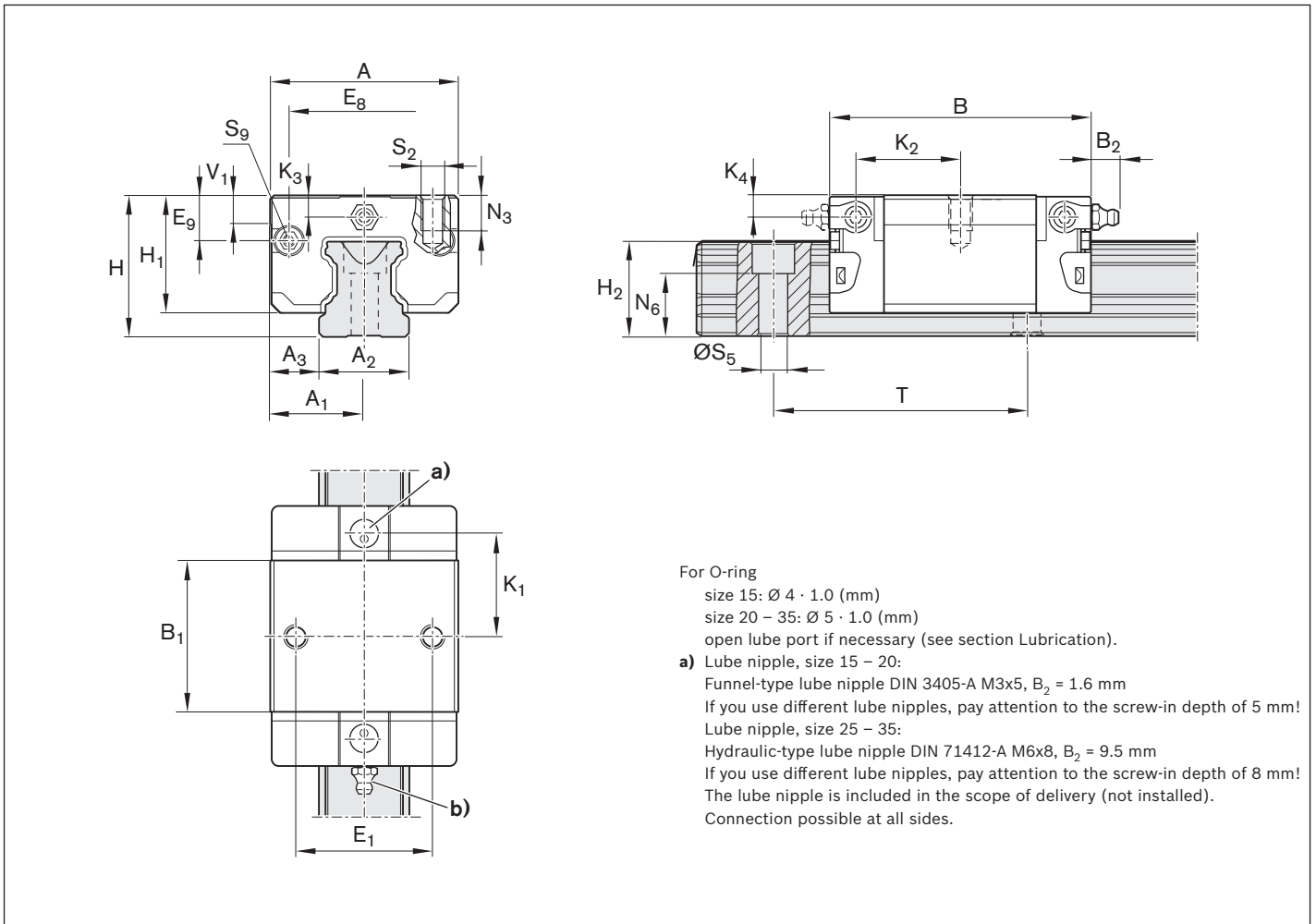

Size	Dimensions (mm)																	
	A	A <sub>1</sub>	A <sub>2</sub>	A <sub>3</sub>	B <sup>+0.5</sup>	B <sub>1</sub>	E <sub>1</sub>	E <sub>8</sub>	E <sub>9</sub>	H	H <sub>1</sub>	H <sub>2</sub> <sup>1)</sup>	H <sub>2</sub> <sup>2)</sup>	K <sub>1</sub>	K <sub>2</sub>	K <sub>3</sub>	K <sub>4</sub>	
15	34	17	15	9.5	44.7	25.7	26	24.55	6.70	24	19.90	16.30	16.20	16.25	17.85	3.20	3.20	
20	44	22	20	12.0	57.3	31.9	32	32.50	7.30	30	25.35	20.75	20.55	22.95	22.95	3.35	3.35	
25	48	24	23	12.5	67.0	38.6	35	38.30	11.50	36	29.90	24.45	24.25	25.35	26.50	5.50	5.50	
30	60	30	28	16.0	75.3	45.0	40	48.40	14.60	42	35.35	28.55	28.35	28.80	30.50	6.05	6.05	
35	70	35	34	18.0	84.9	51.4	50	58.00	17.35	48	40.40	32.15	31.85	32.70	34.20	6.90	6.90	

Size	Dimensions (mm)								Weight (kg)	Load capacities <sup>3)</sup> (N)		Load moments <sup>3)</sup> (Nm)			
	N <sub>3</sub>	N <sub>6</sub> <sup>±0.5</sup>	S <sub>2</sub>	S <sub>5</sub>	S <sub>9</sub>	T	V <sub>1</sub>	m		C	C <sub>0</sub>	M <sub>t</sub>	M <sub>t0</sub>	M <sub>L</sub>	M <sub>L0</sub>
15	6.0	10.3	M4	4.5	M2.5x3.5	60	5.0	0.10	6 720	7 340	65	71	29	32	
20	7.5	13.2	M5	6.0	M3x5	60	6.0	0.25	15 400	16 500	200	210	83	89	
25	9.0	15.2	M6	7.0	M3x5	60	7.5	0.35	19 800	21 200	280	300	130	140	
30	12.0	17.0	M8	9.0	M3x5	80	7.0	0.60	25 600	28 900	440	500	200	230	
35	13.0	20.5	M8	9.0	M3x5	80	8.0	0.90	36 600	49 300	790	1 060	340	460	

- 1) Dimension H<sub>2</sub> with cover strip
- 2) Dimension H<sub>2</sub> without cover strip
- 3) Load capacities and load moments for ball runner blocks **without** ball chain. Load capacities and load moments for ball runner blocks **with** ball chain. 12

Determination of the dynamic load capacities and load moments is based on a 100,000 m travel life according to DIN ISO14728-1. Often only 50,000 m are actually stipulated. For comparison: Multiply values **C**, **M<sub>t</sub>** and **M<sub>L</sub>** by 1.26 according to the table.