

## FKS – Flange, short, standard height R1665 ... 2.

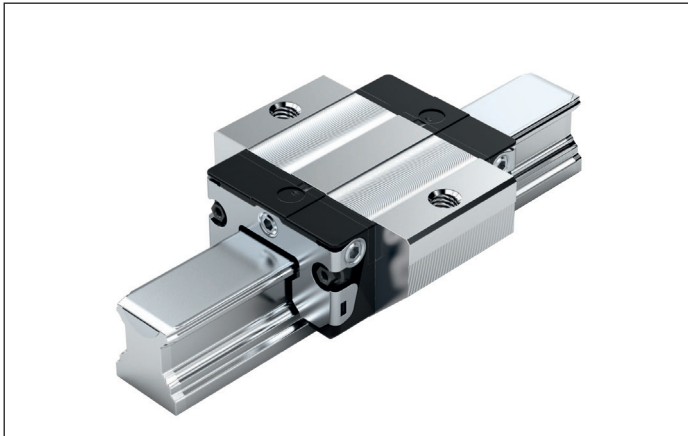

### Dynamic characteristics

Travel speed:  $v_{\max} = 5 \text{ m/s}$

Acceleration:  $a_{\max} = 500 \text{ m/s}^2$

(If  $F_{\text{comb}} > 2.8 \cdot F_{\text{pr}}$ :  $a_{\max} = 50 \text{ m/s}^2$ )

### Note on lubrication

- ▶ Pre-lubricated

### Note

For all SNS/SNO ball guide rails.

### Options and part numbers

Size	Ball runner block with size	Preload class		Accuracy class		Seal with ball runner blocks					
		C0	C1	N	H	without ball chain			with ball chain		
						SS	LS	DS	SS	LS	DS
15	R1665 1	9		4	3	20	21	–	22	23	–
			1	4	3	20	21	–	22	23	–
20	R1665 8	9		4	3	20	21	–	22	23	–
			1	4	3	20	21	2Z	22	23	2Y
25	R1665 2	9		4	3	20	21	–	22	23	–
			1	4	3	20	21	2Z	22	23	2Y
30	R1665 7	9		4	3	20	21	–	22	23	–
			1	4	3	20	21	2Z	22	23	2Y
35	R1665 3	9		4	3	20	21	–	22	23	–
			1	4	3	20	21	2Z	22	23	2Y
e.g.	R1665 7		1		3	20					

### Order example

Options:

- ▶ FKS ball runner block
- ▶ Size 30
- ▶ Preload class C1
- ▶ Accuracy class H
- ▶ With standard seal, without ball chain

Part number:

R1665 713 20

### Preload classes

C0 = Without preload (clearance)  
C1 = Moderate preload

### Seals

SS = standard seal  
LS = low-friction seal  
DS = double-lipped seal

### Key

Gray digits  
= No preferred variant/combination  
(Some delivery times may be longer)

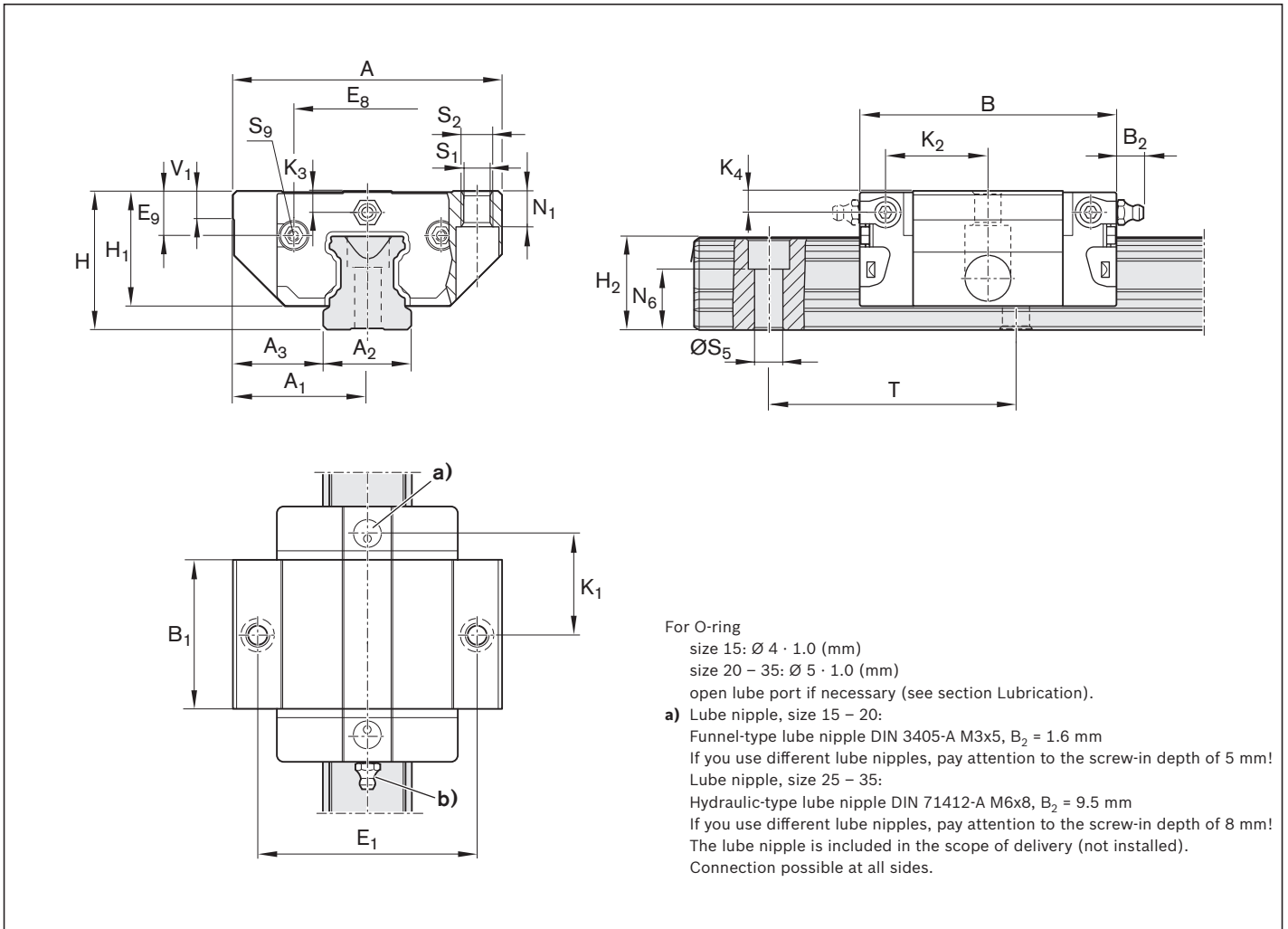

Size	Dimensions (mm)																	
	A	A <sub>1</sub>	A <sub>2</sub>	A <sub>3</sub>	B <sup>+0.5</sup>	B <sub>1</sub>	E <sub>1</sub>	E <sub>8</sub>	E <sub>9</sub>	H	H <sub>1</sub>	H <sub>2</sub> <sup>1)</sup>	H <sub>2</sub> <sup>2)</sup>	K <sub>1</sub>	K <sub>2</sub>	K <sub>3</sub>	K <sub>4</sub>	
15	47	23.5	15	16.0	44.7	25.7	38	24.55	6.70	24	19.90	16.30	16.20	16.25	17.85	3.20	3.20	
20	63	31.5	20	21.5	57.3	31.9	53	32.50	7.30	30	25.35	20.75	20.55	22.95	22.95	3.35	3.35	
25	70	35.0	23	23.5	67.0	38.6	57	38.30	11.50	36	29.90	24.45	24.25	25.35	26.50	5.50	5.50	
30	90	45.0	28	31.0	75.3	45.0	72	48.40	14.60	42	35.35	28.55	28.35	28.80	30.50	6.05	6.05	
35	100	50.0	34	33.0	84.9	51.4	82	58.00	17.35	48	40.40	32.15	31.85	32.70	34.20	6.90	6.90	

Size	Dimensions (mm)										Weight (kg)	Load capacities <sup>3)</sup> (N)		Load moments <sup>3)</sup> (Nm)			
	N <sub>1</sub>	N <sub>6</sub> <sup>±0.5</sup>	S <sub>1</sub>	S <sub>2</sub>	S <sub>5</sub>	S <sub>9</sub>	T	V <sub>1</sub>	m	C		C <sub>0</sub>	M <sub>t</sub>	M <sub>t0</sub>	M <sub>L</sub>	M <sub>L0</sub>	
15	5.2	10.3	4.3	M5	4.5	M2.5x3.5	60	5.0	0.15	6 720	7 340	65	71	29	32		
20	7.7	13.2	5.3	M6	6.0	M3x5	60	6.0	0.30	15 400	16 500	200	210	83	89		
25	9.3	15.2	6.7	M8	7.0	M3x5	60	7.5	0.50	19 800	21 200	280	300	130	140		
30	11.0	17.0	8.5	M10	9.0	M3x5	80	7.0	0.80	25 600	28 900	440	500	200	230		
35	12.0	20.5	8.5	M10	9.0	M3x5	80	8.0	1.20	36 600	49 300	790	1 060	340	460		

- 1) Dimension H<sub>2</sub> with cover strip
  - 2) Dimension H<sub>2</sub> without cover strip
  - 3) Load capacities and load moments for ball runner blocks **without** ball chain. Load capacities and load moments for ball runner blocks **with** ball chain. 12
- Determination of the dynamic load capacities and load moments is based on a 100,000 m travel life according to DIN ISO14728-1. Often only 50,000 m are actually stipulated. For comparison: Multiply values **C**, **M<sub>t</sub>** and **M<sub>L</sub>** by 1.26 according to the table.