



EVL-SERIES

- Industry standard mounting dimensions
- Large variety of reduction ratios to choose from
- Thread-in mounting style
- Best-in-class value for right-angle reducers
- Low backlash (≤ 6 arc-min)
- Space-saving design when minimal envelope available
- Readily available

EVL-SERIES Right-angle shaft

EVL-Series – Features

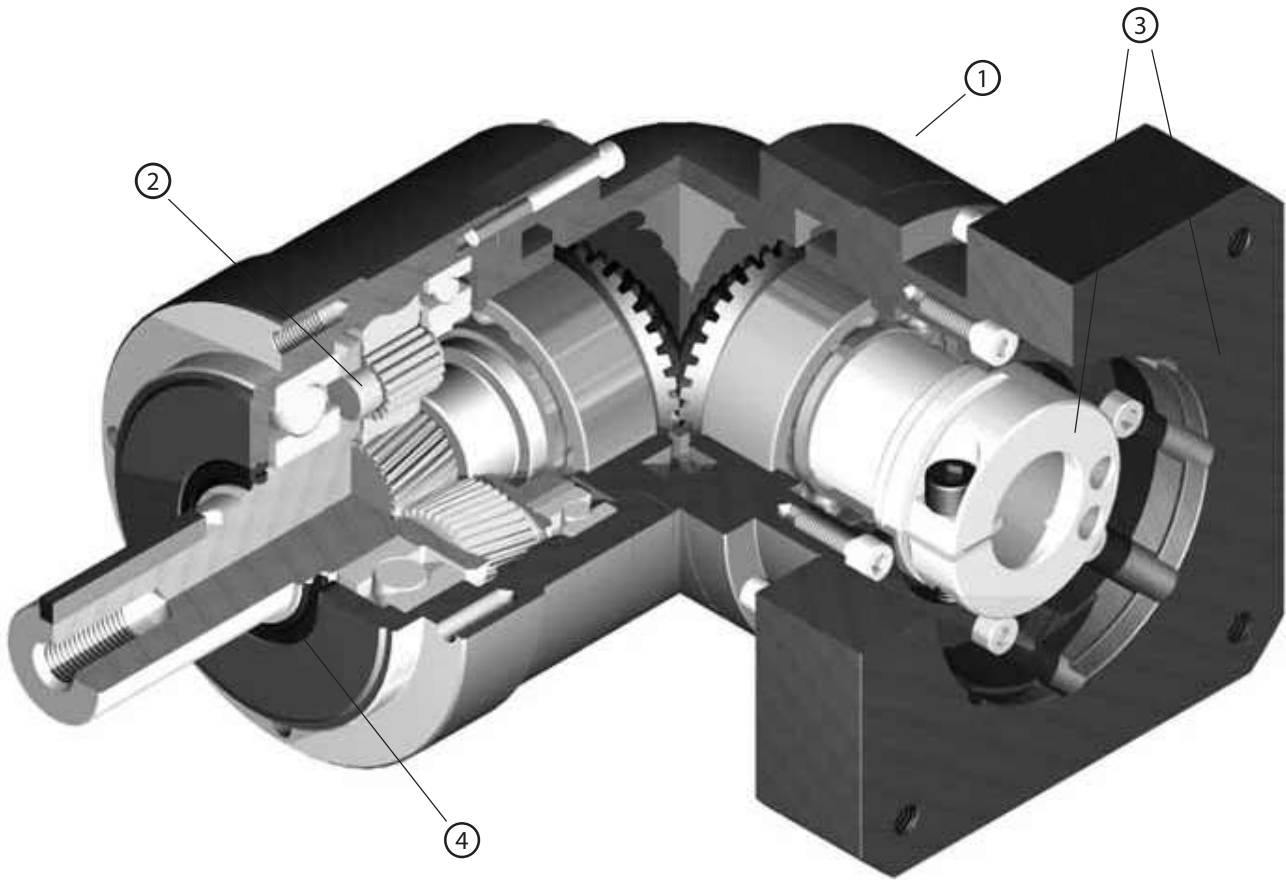

- ① Space-saving features, motor can be located at a 90 degree position from the reducer providing a more compact footprint
- ② High rigidity and torque capacity are achieved by using uncaged needle roller bearings
- ③ Adapter-bushing connection, enable a simple, effective attachment to most servo motors
- ④ No leakage through the seal, high viscosity, anti-separation grease does not liquefy and does not migrate away from the gears
- ⑤ No need to replace the grease for the life of the unit. The reducer can be positioned in any orientation

EVL-Series – Model Code

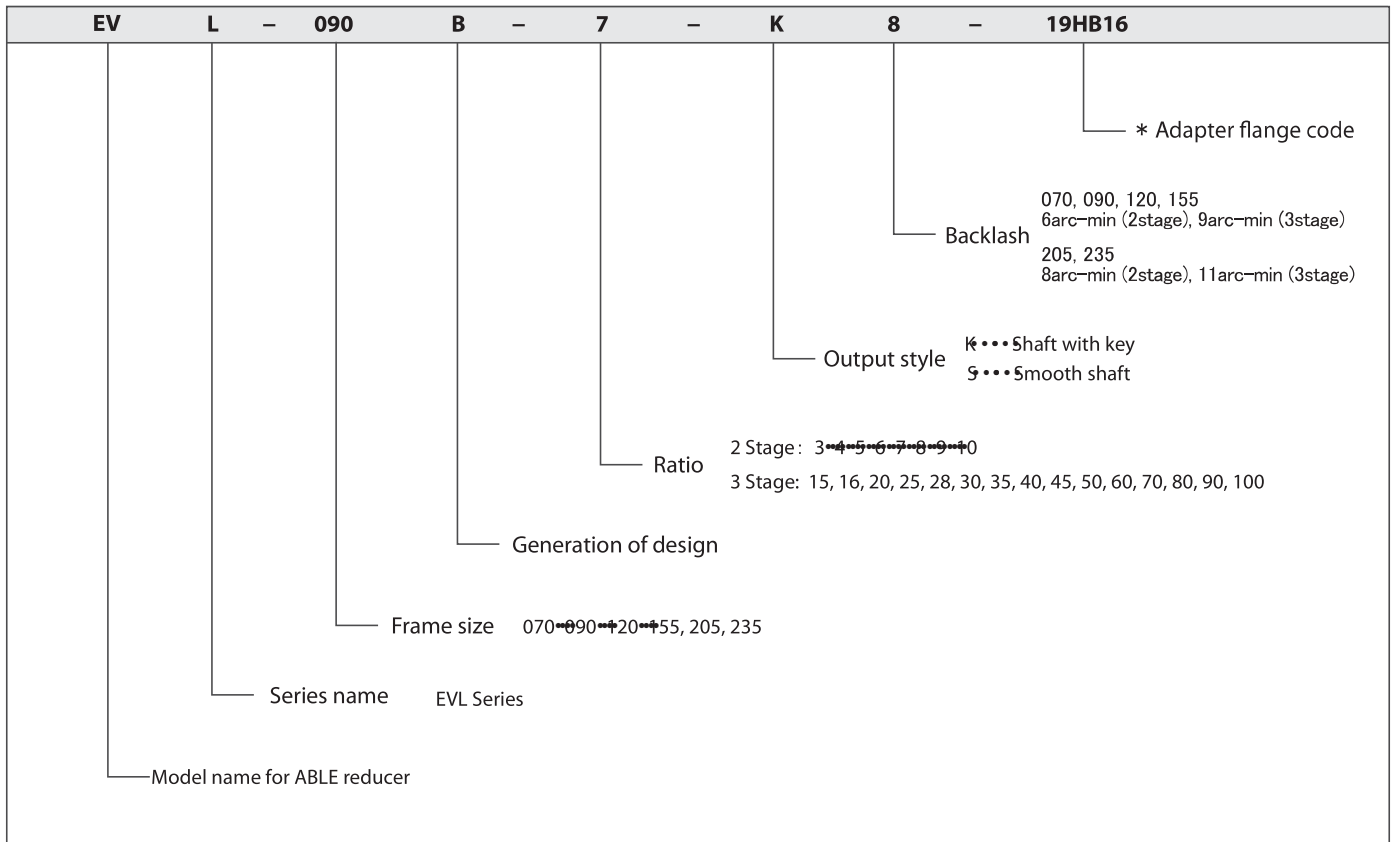

*1) Adapter flange code
 Adapter flange code varies depending on the motor.

EVL

Contact us for additional information or refer to our online reducer selection tool.
 Selection tool www.nidec-shimpo.co.jp/selection/eng

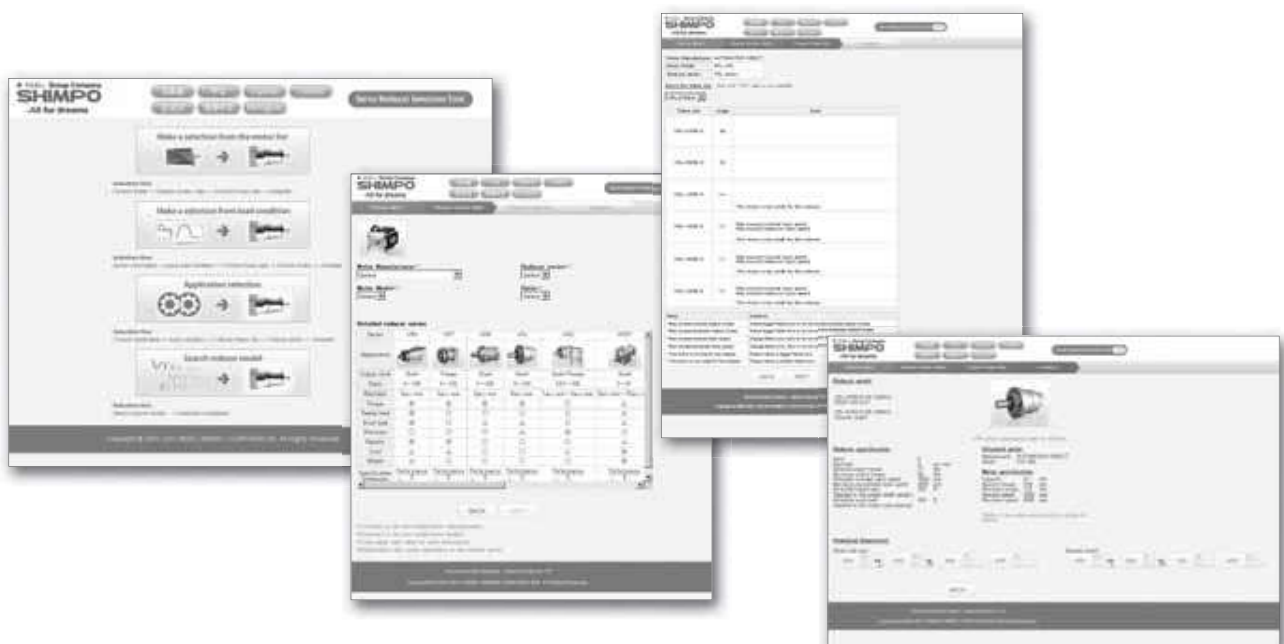

EVL-SERIES Right-angle shaft

EVL-070 – 2-Stage Specifications

Frame Size	070									
Stage	2-Stage									
Ratio	Unit	Note	3	4	5	6	7	8	9	10
Nominal Output Torque	[Nm]	*1	12	16	22	24	24	24	16	16
Maximum Acceleration Torque	[Nm]	*2	24	32	40	45	45	45	32	32
Emergency Stop Torque	[Nm]	*3	50	65	80	90	90	90	65	65
Nominal Input Speed	[rpm]	*4	3000							
Maximum Input Speed	[rpm]	*5	6000							
No Load Running Torque	[Nm]	*6	0.33							
Permitted Radial Load	[N]	*7	430	470	510	540	570	600	620	640
Permitted Axial Load	[N]	*8	310	360	390	430	460	480	510	530
Maximum Radial Load	[N]	*9	1200							
Maximum Axial Load	[N]	*10	1100							
Moment of Inertia ($\leq \varnothing 8$)	[kgcm ²]	--	0.310	0.270	0.250	0.240	0.230	0.230	0.230	0.230
Moment of Inertia ($\leq \varnothing 14$)	[kgcm ²]	--	0.390	0.340	0.320	0.310	0.310	0.310	0.300	0.300
Moment of Inertia ($\leq \varnothing 19$)	[kgcm ²]	--	0.580	0.530	0.510	0.500	0.500	0.500	0.490	0.490
Efficiency	[%]	*11	93							
Torsional Rigidity	[Nm/arc-min]	*12	3							
Maximum Torsional Backlash	[arc-min]	--	≤ 6							
Noise Level	[dB]	*13	80							
Protection Class	--	*14	IP54 (IP65)							
Ambient Temperature	[°C]	--	0-40							
Permitted Housing Temperature	[°C]	--	90							
Weight	[kg]	*15	1.9							

EVL-070 – 3-Stage Specifications

Frame Size	070									
Stage	3-Stage									
Ratio	Unit	Note	15	16	20	25	28	30	35	40
Nominal Output Torque	[Nm]	*1	16	24	24	24	24	16	24	24
Maximum Acceleration Torque	[Nm]	*2	32	45	45	45	45	32	45	45
Emergency Stop Torque	[Nm]	*3	65	90	90	90	90	65	90	90
Nominal Input Speed	[rpm]	*4	3000							
Maximum Input Speed	[rpm]	*5	6000							
No Load Running Torque	[Nm]	*6	0.20							
Permitted Radial Load	[N]	*7	740	750	810	870	910	930	980	100
Permitted Axial Load	[N]	*8	630	650	720	790	830	860	920	970
Maximum Radial Load	[N]	*9	1200							
Maximum Axial Load	[N]	*10	1100							
Moment of Inertia ($\leq \varnothing 8$)	[kgcm ²]	--	0.073	0.079	0.071	0.071	0.077	0.062	0.070	0.061
Moment of Inertia ($\leq \varnothing 14$)	[kgcm ²]	--	0.118	0.124	0.116	0.115	0.122	0.106	0.115	0.106
Moment of Inertia ($\leq \varnothing 19$)	[kgcm ²]	--	--	--	--	--	--	--	--	--
Efficiency	[%]	*11	88							
Torsional Rigidity	[Nm/arc-min]	*12	3							
Maximum Torsional Backlash	[arc-min]	--	≤ 9							
Noise Level	[dB]	*13	80							
Protection Class	--	*14	IP54 (IP65)							
Ambient Temperature	[°C]	--	0-40							
Permitted Housing Temperature	[°C]	--	90							
Weight	[kg]	*15	1.7							

EVL-070 – 3-Stage Specifications

Frame Size	070										
Stage	3-Stage										
Ratio	Unit	Note	45	50	60	70	80	90	100		
Nominal Output Torque	[Nm]	*1	16	24	24	24	24	16	16		
Maximum Acceleration Torque	[Nm]	*2	32	45	45	45	45	32	32		
Emergency Stop Torque	[Nm]	*3	65	90	90	90	90	65	65		
Nominal Input Speed	[rpm]	*4	3000								
Maximum Input Speed	[rpm]	*5	6000								
No Load Running Torque	[Nm]	*6	0.20								
Permitted Radial Load	[N]	*7	1100	1100	1200	1200	1200	1200	1200		
Permitted Axial Load	[N]	*8	1000	1100	1100	1100	1100	1100	1100		
Maximum Radial Load	[N]	*9	1200								
Maximum Axial Load	[N]	*10	1100								
Moment of Inertia (≤ Ø 8)	[kgcm ²]	--	0.070	0.061	0.061	0.061	0.061	0.061	0.061		
Moment of Inertia (≤ Ø 14)	[kgcm ²]	--	0.115	0.106	0.106	0.105	0.105	0.105	0.105		
Moment of Inertia (≤ Ø 19)	[kgcm ²]	--	--	--	--	--	--	--	--		
Efficiency	[%]	*11	88								
Torsional Rigidity	[Nm/arc-min]	*12	3								
Maximum Torsional Backlash	[arc-min]	--	≤ 9								
Noise Level	[dB]	*13	80								
Protection Class	--	*14	IP54 (IP65)								
Ambient Temperature	[°C]	--	0-40								
Permitted Housing Temperature	[°C]	--	90								
Weight	[kg]	*15	1.7								

- *1) At nominal input speed, service life is 20,000 hours
- *2) The maximum torque when starting or stopping operation
- *3) The maximum torque allowed under a stress situation (Permitted 1,000 times during service life)
- *4) The average input speed
- *5) The maximum intermittent input speed
- *6) This is the torque at no load applied on the input shaft. The input speed is 3000 rpm for EVL070
- *7) At this load and nominal input speed, service life will be 20,000 hours. (The radial load applied to the output side bearing)
- *8) At this load and nominal input speed, service life will be 20,000 hours. (The axial load applied to the output shaft center)
- *9) The maximum radial load that the reducer can accept
- *10) The maximum axial load that the reducer can accept
- *11) The efficiency at the nominal torque rating
- *12) This does not include the lost motion
- *13) Contact NIDEC-SHIMPO for the testing conditions and environment
- *14) IP65 (wash-down) is available as an option. Contact NIDEC-SHIMPO for more details and our food grade options
- *15) The weight may vary slightly between models

EVL-SERIES Right-angle shaft

EVL-070 – 2-Stage Dimensions

Input shaft bore $\cong \varnothing 8$

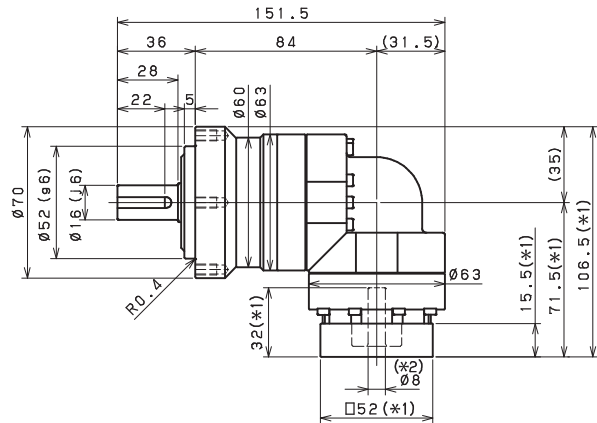
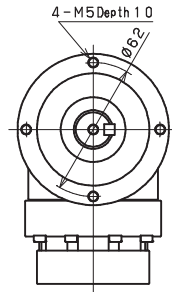

Input shaft bore $\cong \varnothing 14$

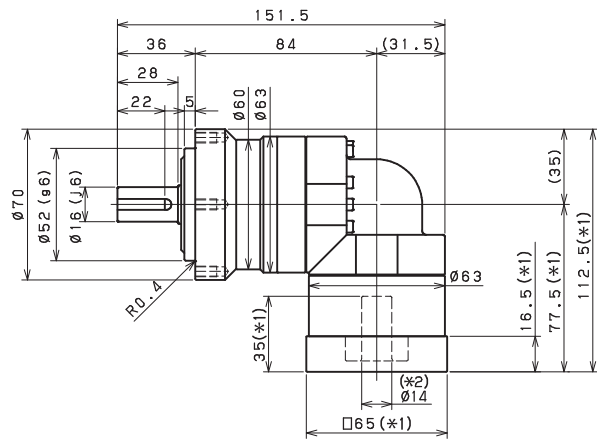
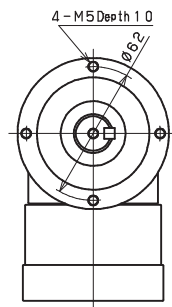

Input shaft bore $\cong \varnothing 19$

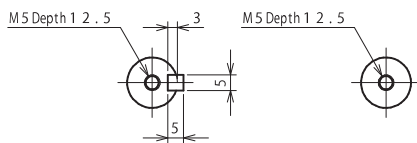
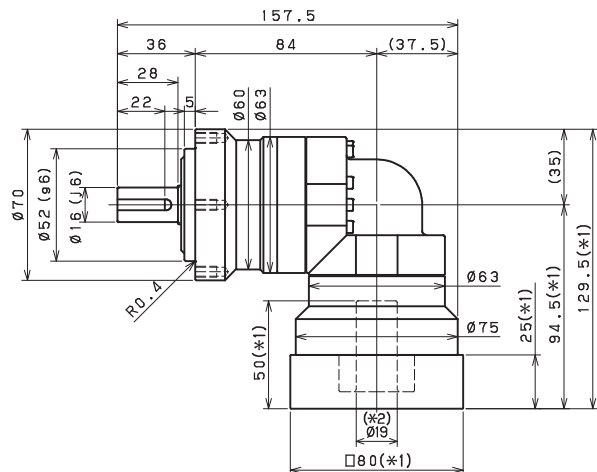
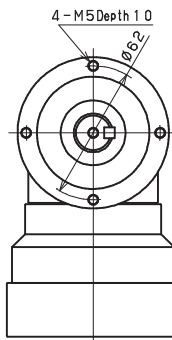

Shaft with key

Smooth shaft

- *1) Length will vary depending on motor
- *2) Bushing will be inserted to adapt to motor shaft

EVL-070 – 3-Stage Dimensions

Input shaft bore $\cong \varnothing 8$

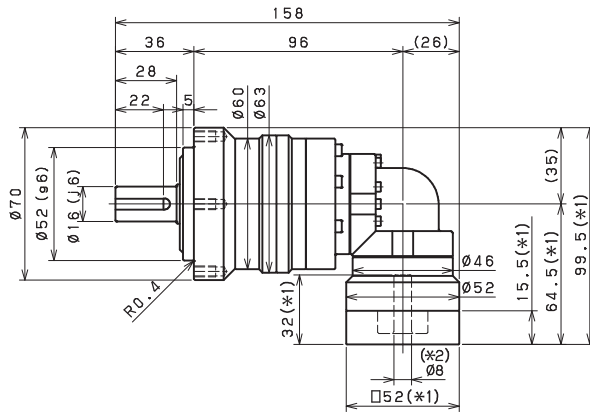
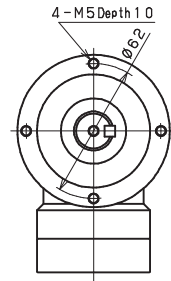

Input shaft bore $\cong \varnothing 14$

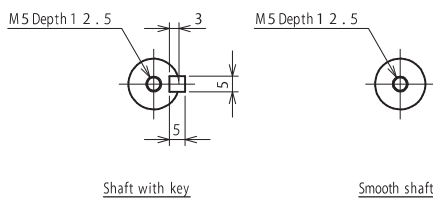
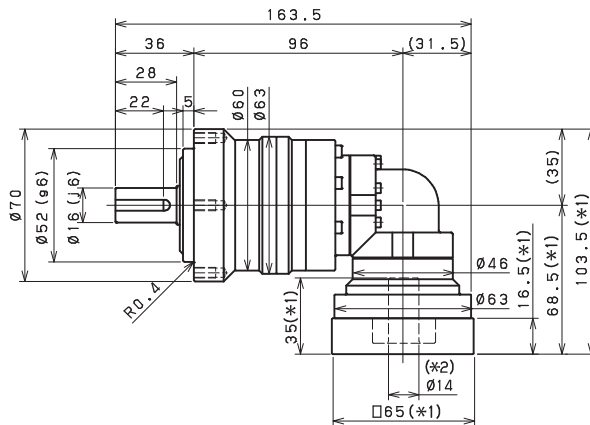
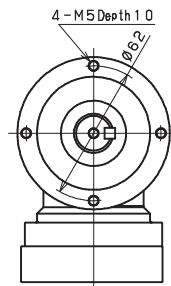

- *1) Length will vary depending on motor
- *2) Bushing will be inserted to adapt to motor shaft

EVL-SERIES Right-angle shaft

EVL-070 – 2-Stage Adapter Dimensions

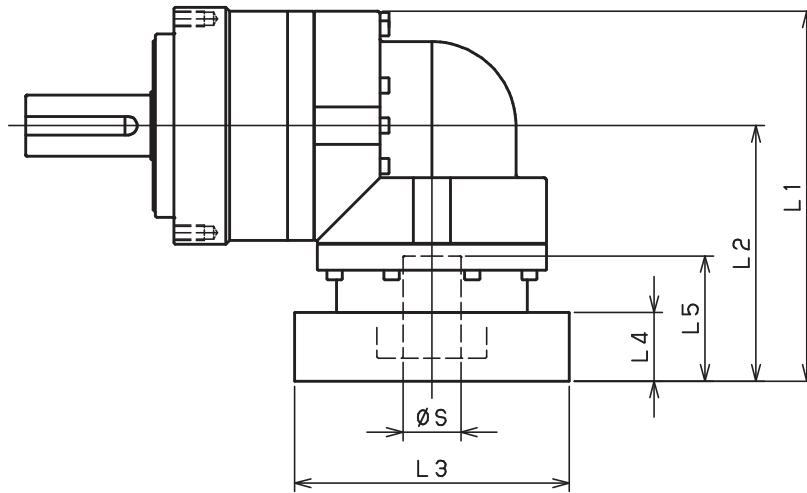

Model number	**: Adapter code	2-Stage				
		L1	L2	L3	L4	L5
EVL-070-□-□-8** (S ≤ 8)	AA·AC·AD·AF·AG·AL·AM·AN·AQ	106.5	71.5	□52	15.5	32
	AB·AE·AH·AJ·AK	111.5	76.5	□52	20.5	37
	BA·BB·BD·BE·BG·BH·BJ	106.5	71.5	□60	15.5	32
	BC·BF	111.5	76.5	□60	20.5	37
	CA	111.5	76.5	□70	20.5	37
EVL-070-□-□-14** (8 < S ≤ 14)	BA·BB·BD·BE·BF·BG·BH·BJ·BK·BP	112.5	77.5	□65	16.5	35
	BC·BH·BM·BN	117.5	82.5	□65	21.5	40
	BL	122.5	87.5	□65	26.5	45
	CA·CC	112.5	77.5	□70	16.5	35
	CB	117.5	82.5	□70	21.5	40
	DA·DB·DC·DD·DF·DH·DJ	112.5	77.5	□80	16.5	35
	DE·DL	117.5	82.5	□80	21.5	40
	DG·DK	122.5	87.5	□80	26.5	45
	EA·EB·EC·EF·EG·EK·EL	112.5	77.5	□90	16.5	35
	EJ·EM	117.5	82.5	□90	21.5	40
	ED·EE·EH	122.5	87.5	□90	26.5	45
	FA	112.5	77.5	□100	16.5	35
FB	122.5	87.5	□100	26.5	45	
EVL-070-□-□-19** (14 < S ≤ 19)	DA·DB·DC	129.5	94.5	□80	25	50
	DD	139.5	104.5	□80	35	60
	DE	134.5	99.5	□80	30	55
	EA	134.5	99.5	□90	30	55
	EB·ED	129.5	94.5	□90	25	50
	EC	139.5	104.5	□90	35	60
	FA	129.5	94.5	□100	25	50
FB	139.5	104.5	□100	35	60	

*1) Double reduction : 1/3~ 1/10

*2) Bushing will be inserted to adapt to motor shaft

For an explanation on the Adapter Flange Code, please turn to page 422.

A more comprehensive adapter flange offering can be found using the NIDEC-SHIMPO Online Selector Tool. The variety is constantly expanding and being updated on the Selector Tool. If you have any questions or need any support, contact NIDEC-SHIMPO.

EVL-070 – 3-Stage Adapter Dimensions

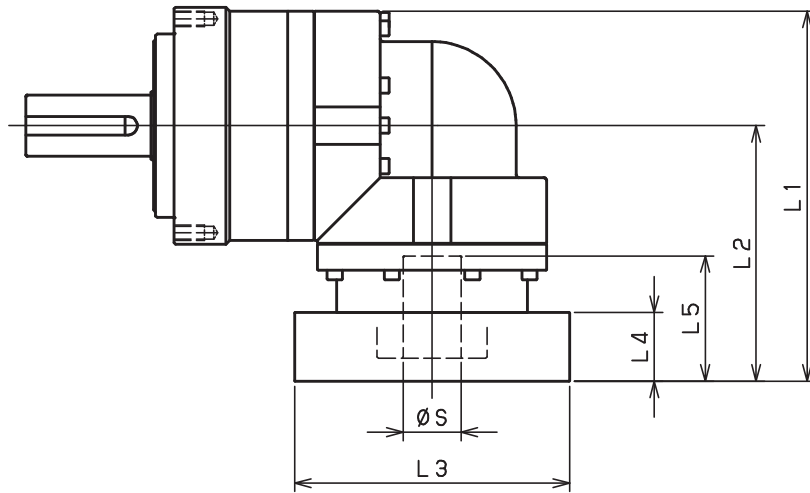

Model number	**: Adapter code	3-Stage				
		L1	L2	L3	L4	L5
EVL-070-□-□-8** (S ≤ 8)	AA·AC·AD·AF·AG·AL·AM·AN·AQ	99.5	64.5	□52	15.5	32
	AB·AE·AH·AJ·AK	104.5	69.5	□52	20.5	37
	BA·BB·BD·BE·BG·BH·BJ	99.5	64.5	□60	15.5	32
	BC·BF	104.5	69.5	□60	20.5	37
	CA	104.5	69.5	□70	20.5	37
EVL-070-□-□-14** (8 < S ≤ 14)	BA·BB·BD·BE·BF·BG·BH·BJ·BK·BP	103.5	68.5	□65	16.5	35
	BC·BH·BM·BN	108.5	73.5	□65	21.5	40
	BL	113.5	78.5	□65	26.5	45
	CA·CC	103.5	68.5	□70	16.5	35
	CB	108.5	73.5	□70	21.5	40
	DA·DB·DC·DD·DF·DH·DJ	103.5	68.5	□80	16.5	35
	DE·DL	108.5	73.5	□80	21.5	40
	DG·DK	113.5	78.5	□80	26.5	45
	EA·EB·EC·EF·EG·EK·EL	103.5	68.5	□90	16.5	35
	EJ·EM	108.5	73.5	□90	21.5	40
	ED·EE·EH	113.5	78.5	□90	26.5	45
	FA	103.5	68.5	□100	16.5	35
	FB	113.5	78.5	□100	26.5	45
EVL-070-□-□-19** (14 < S ≤ 19)	DA·DB·DC	--	--	--	--	--
	DD	--	--	--	--	--
	DE	--	--	--	--	--
	EA	--	--	--	--	--
	EB·ED	--	--	--	--	--
	EC	--	--	--	--	--
	FA	--	--	--	--	--

*1) Triple reduction : 1/15~ 1/100

*2) Bushing will be inserted to adapt to motor shaft

For an explanation on the Adapter Flange Code, please turn to page 422.

A more comprehensive adapter flange offering can be found using the NIDEC-SHIMPO Online Selector Tool. The variety is constantly expanding and being updated on the Selector Tool. If you have any questions or need any support, contact NIDEC-SHIMPO.

EVL-SERIES Right-angle shaft

EVL-090 – 2-Stage Specifications

Frame Size	090									
Stage	2-Stage									
Ratio	Unit	Note	3	4	5	6	7	8	9	10
Nominal Output Torque	[Nm]	*1	45	60	65	65	65	65	45	45
Maximum Acceleration Torque	[Nm]	*2	65	90	90	90	90	90	65	65
Emergency Stop Torque	[Nm]	*3	130	170	220	220	220	220	170	170
Nominal Input Speed	[rpm]	*4	3000							
Maximum Input Speed	[rpm]	*5	6000							
No Load Running Torque	[Nm]	*6	1.13							
Permitted Radial Load	[N]	*7	810	890	960	1000	1100	1100	1200	1200
Permitted Axial Load	[N]	*8	930	1100	1200	1300	1300	1400	1500	1600
Maximum Radial Load	[N]	*9	2400							
Maximum Axial Load	[N]	*10	2200							
Moment of Inertia ($\leq \varnothing 8$)	[kgcm ²]	--	--	--	--	--	--	--	--	--
Moment of Inertia ($\leq \varnothing 14$)	[kgcm ²]	--	2.120	1.890	1.800	1.760	1.730	1.710	1.700	1.690
Moment of Inertia ($\leq \varnothing 19$)	[kgcm ²]	--	2.450	2.220	2.130	2.090	2.060	2.040	2.030	2.020
Moment of Inertia ($\leq \varnothing 28$)	[kgcm ²]	--	4.570	4.350	4.260	4.210	4.180	4.170	4.160	4.150
Efficiency	[%]	*11	93							
Torsional Rigidity	[Nm/arc-min]	*12	10							
Maximum Torsional Backlash	[arc-min]	--	≤ 6							
Noise Level	[dB]	*13	80							
Protection Class	--	*14	IP54 (IP65)							
Ambient Temperature	[°C]	--	0-40							
Permitted Housing Temperature	[°C]	--	90							
Weight	[kg]	*15	4.9							

EVL-090 – 3-Stage Specifications

Frame Size	090									
Stage	3-Stage									
Ratio	Unit	Note	15	16	20	25	28	30	35	40
Nominal Output Torque	[Nm]	*1	45	65	65	65	65	45	65	65
Maximum Acceleration Torque	[Nm]	*2	65	110	110	110	110	65	110	110
Emergency Stop Torque	[Nm]	*3	170	220	220	220	220	170	220	220
Nominal Input Speed	[rpm]	*4	3000							
Maximum Input Speed	[rpm]	*5	6000							
No Load Running Torque	[Nm]	*6	0.55							
Permitted Radial Load	[N]	*7	1400	1400	1500	1600	1700	1700	1800	1900
Permitted Axial Load	[N]	*8	1900	1900	2100	2200	2200	2200	2200	2200
Maximum Radial Load	[N]	*9	2400							
Maximum Axial Load	[N]	*10	2200							
Moment of Inertia ($\leq \varnothing 8$)	[kgcm ²]	--	0.340	0.380	0.330	0.320	0.370	0.250	0.320	0.250
Moment of Inertia ($\leq \varnothing 14$)	[kgcm ²]	--	0.410	0.460	0.400	0.400	0.450	0.330	0.400	0.320
Moment of Inertia ($\leq \varnothing 19$)	[kgcm ²]	--	0.600	0.650	0.590	0.590	0.640	0.510	0.590	0.510
Moment of Inertia ($\leq \varnothing 28$)	[kgcm ²]	--	--	--	--	--	--	--	--	--
Efficiency	[%]	*11	88							
Torsional Rigidity	[Nm/arc-min]	*12	10							
Maximum Torsional Backlash	[arc-min]	--	≤ 9							
Noise Level	[dB]	*13	80							
Protection Class	--	*14	IP54 (IP65)							
Ambient Temperature	[°C]	--	0-40							
Permitted Housing Temperature	[°C]	--	90							
Weight	[kg]	*15	4.3							

EVL-090 – 3-Stage Specifications

Frame Size	090										
Stage	3-Stage										
Ratio	Unit	Note	45	50	60	70	80	90	100		
Nominal Output Torque	[Nm]	*1	45	65	65	65	65	45	45		
Maximum Acceleration Torque	[Nm]	*2	65	110	1110	110	110	65	65		
Emergency Stop Torque	[Nm]	*3	170	220	220	220	220	170	170		
Nominal Input Speed	[rpm]	*4	3000								
Maximum Input Speed	[rpm]	*5	6000								
No Load Running Torque	[Nm]	*6	0.55								
Permitted Radial Load	[N]	*7	2000	2100	2200	2300	2400	2400	2400		
Permitted Axial Load	[N]	*8	2200	2200	2200	2200	2200	2200	2200		
Maximum Radial Load	[N]	*9	2400								
Maximum Axial Load	[N]	*10	2200								
Moment of Inertia (≤ Ø 8)	[kgcm ²]	--	0.320	0.250	0.250	0.250	0.250	0.250	0.250		
Moment of Inertia (≤ Ø 14)	[kgcm ²]	--	0.390	0.320	0.320	0.320	0.320	0.320	0.320		
Moment of Inertia (≤ Ø 19)	[kgcm ²]	--	0.580	0.510	0.510	0.510	0.510	0.510	0.510		
Moment of Inertia (≤ Ø 28)	[kgcm ²]	--	--	--	--	--	--	--	--		
Efficiency	[%]	*11	88								
Torsional Rigidity	[Nm/arc-min]	*12	10								
Maximum Torsional Backlash	[arc-min]	--	≤ 9								
Noise Level	[dB]	*13	80								
Protection Class	--	*14	IP54 (IP65)								
Ambient Temperature	[°C]	--	0-40								
Permitted Housing Temperature	[°C]	--	90								
Weight	[kg]	*15	4.3								

- *1) At nominal input speed, service life is 20,000 hours
- *2) The maximum torque when starting or stopping operation
- *3) The maximum torque allowed under a stress situation (Permitted 1,000 times during service life)
- *4) The average input speed
- *5) The maximum intermittent input speed
- *6) This is the torque at no load applied on the input shaft. The input speed is 3000 rpm for EVL090
- *7) At this load and nominal input speed, service life will be 20,000 hours. (The radial load applied to the output side bearing)
- *8) At this load and nominal input speed, service life will be 20,000 hours. (The axial load applied to the output shaft center)
- *9) The maximum radial load that the reducer can accept
- *10) The maximum axial load that the reducer can accept
- *11) The efficiency at the nominal torque rating
- *12) This does not include the lost motion
- *13) Contact NIDEC-SHIMPO for the testing conditions and environment
- *14) IP65 (wash-down) is available as an option. Contact NIDEC-SHIMPO for more details and our food grade options
- *15) The weight may vary slightly between models

EVL-090 – 3-Stage Dimensions

Input shaft bore $\leq \varnothing 8$

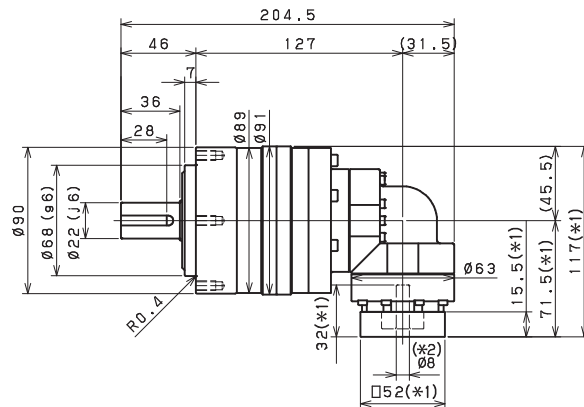
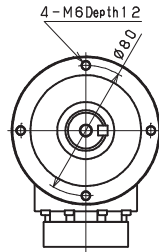

Input shaft bore $\leq \varnothing 14$

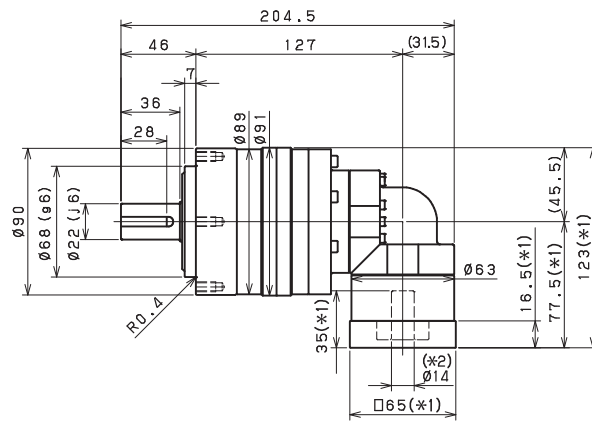
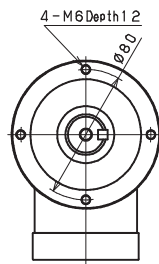

Input shaft bore $\leq \varnothing 19$

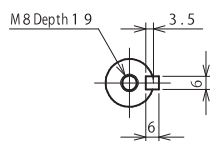
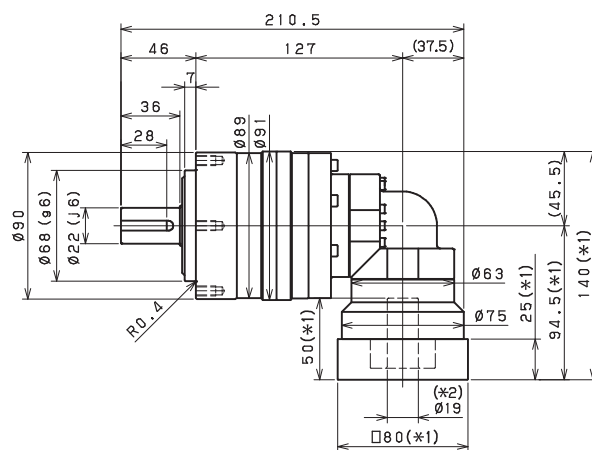
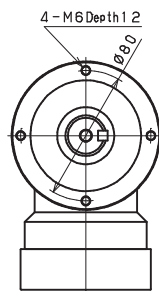

Shaft with key

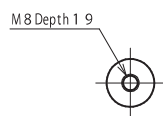

Smooth shaft

*1) Length will vary depending on motor.

*2) Bushing will be inserted to adapt to motor shaft

EVL-SERIES Right-angle shaft

EVL-090 – 2-Stage Adapter Dimensions

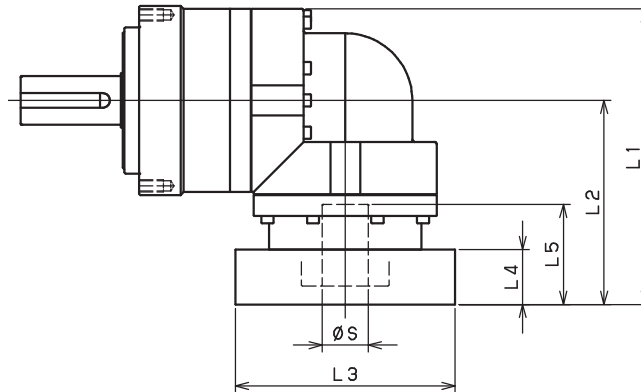

Model number	**: Adapter code	2-Stage				
		L1	L2	L3	L4	L5
EVL-090-□-□-8** (S ≤ 8)	AA·AC·AD·AF·AG·AL·AM·AN·AQ	--	--	--	--	--
	AB·AE·AH·AJ·AK	--	--	--	--	--
	BA·BB·BD·BE·BG·BH·BJ	--	--	--	--	--
	CA	--	--	--	--	--
EVL-090-□-□-14** (8 < S ≤ 14)	BA·BB·BD·BE·BF·BG·BH·BJ·BK·BP	137.5	92	□65	16.5	35
	BC·BH·BM·BN	142.5	97	□65	21.5	40
	CA·CC	137.5	92	□70	16.5	35
	DA·DB·DC·DD·DF·DH·DJ	137.5	92	□80	16.5	35
	EA·EB·EC·EF·EG·EK·EL	137.5	92	□90	16.5	35
	FA	137.5	92	□100	16.5	35
	FB	147.5	102	□100	26.5	45
EVL-090-□-□-19** (14 < S ≤ 19)	DA·DB·DC	145.5	100	□80	25	50
	EB·ED	145.5	100	□90	25	50
	FA	145.5	100	□100	25	50
	FB	155.5	110	□100	35	60
	GA·GC·GH	150.5	105	□115	30	55
	GB·GD·GJ	145.5	100	□115	25	50
	GE·GF	155.5	110	□115	35	60
	HA	145.5	100	□130	25	50
	HB	160.5	115	□130	40	65
	HC·HD·HE	150.5	105	□130	30	55
	JA	155.5	110	□150	35	60
EVL-090-□-□-28** (19 < S ≤ 28)	FA·FB·FC	174.5	129	□100	35	67
	FD·FE	169.5	124	□100	30	62
	GA·GB·GC·GD·GE·GF·GG·GH	174.5	129	□115	35	67
	HA·HC·HD	174.5	129	□130	35	67
	HB	184.5	139	□130	45	77
	HE	189.5	144	□130	50	82
	HF	169.5	124	□130	30	62
	JA·JB·JC·JF	174.5	129	□150	35	67
	JD	194.5	149	□150	55	87
JE	184.5	139	□150	45	77	

*1) Double reduction : 1/3 ~ 1/10

*2) Bushing will be inserted to adapt to motor shaft

For an explanation on the Adapter Flange Code, please turn to page 422.

A more comprehensive adapter flange offering can be found using the NIDEC-SHIMPO Online Selector Tool. The variety is constantly expanding and being updated on the Selector Tool. If you have any questions or need any support, contact NIDEC-SHIMPO.

EVL-090 – 3-Stage Adapter Dimensions

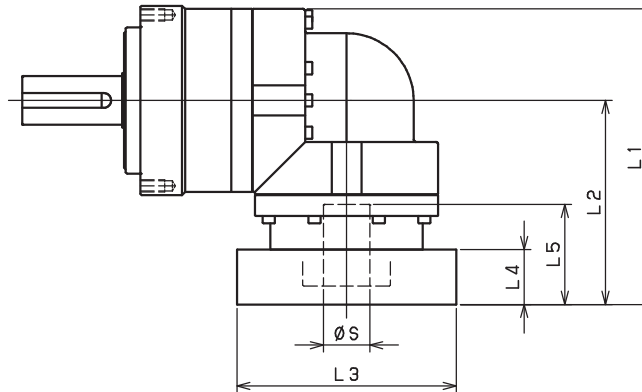

Model number	**: Adapter code	3-Stage				
		L1	L2	L3	L4	L5
EVL-090-□-□-8** (S ≤ 8)	AA·AC·AD·AF·AG·AL·AM·AN·AQ	117	71.5	□52	15.5	32
	AB·AE·AH·AJ·AK	122	76.5	□52	20.5	37
	BA·BB·BD·BE·BG·BH·BJ	117	71.5	□60	15.5	32
	CA	122	76.5	□70	20.5	37
EVL-090-□-□-14** (8 < S ≤ 14)	BA·BB·BD·BE·BF·BG·BH·BJ·BK·BP	123	77.5	□65	16.5	35
	BC·BH·BM·BN	128	82.5	□65	21.5	40
	CA·CC	123	77.5	□70	16.5	35
	DA·DB·DC·DD·DF·DH·DJ	123	77.5	□80	16.5	35
	EA·EB·EC·EF·EG·EK·EL	123	77.5	□90	16.5	35
	FA	123	77.5	□100	16.5	35
	FB	133	87.5	□100	26.5	45
	JA	138	92.5	□150	31.5	50
EVL-090-□-□-19** (14 < S ≤ 19)	DA·DB·DC	140	94.5	□80	25	50
	EB·ED	140	94.5	□90	25	50
	FA	140	94.5	□100	25	50
	FB	150	104.5	□100	35	60
	GA·GC·GH	145	99.5	□115	30	55
	GB·GD·GJ	140	94.5	□115	25	50
	GE·GF	150	104.5	□115	35	60
	HA	140	94.5	□130	25	50
	HB	155	109.5	□130	40	65
	HC·HD·HE	145	99.5	□130	30	55
	JA	150	104.5	□150	35	60
EVL-090-□-□-28** (19 < S ≤ 28)	FA·FB·FC	--	--	--	--	--
	FD·FE	--	--	--	--	--
	GA·GB·GC·GD·GE·GF·GG·GH	--	--	--	--	--
	HA·HC·HD	--	--	--	--	--
	HB	--	--	--	--	--
	HE	--	--	--	--	--
	HF	--	--	--	--	--
	JA·JB·JC·JF	--	--	--	--	--
	JD	--	--	--	--	--
JE	--	--	--	--	--	

*1) Triple reduction : 1/15~ 1/100

*2) Bushing will be inserted to adapt to motor shaft

For an explanation on the Adapter Flange Code, please turn to page 422.

A more comprehensive adapter flange offering can be found using the NIDEC-SHIMPO Online Selector Tool. The variety is constantly expanding and being updated on the Selector Tool. If you have any questions or need any support, contact NIDEC-SHIMPO.

EVL-SERIES Right-angle shaft

EVL-120 – 2-Stage Specifications

Frame Size	120									
Stage	2-Stage									
Ratio	Unit	Note	3	4	5	6	7	8	9	10
Nominal Output Torque	[Nm]	*1	75	100	120	150	150	150	110	110
Maximum Acceleration Torque	[Nm]	*2	150	200	240	300	300	300	200	200
Emergency Stop Torque	[Nm]	*3	320	430	500	550	550	550	450	450
Nominal Input Speed	[rpm]	*4	3000							
Maximum Input Speed	[rpm]	*5	6000							
No Load Running Torque	[Nm]	*6	1.88							
Permitted Radial Load	[N]	*7	1300	1500	1600	1700	1800	1900	1900	2000
Permitted Axial Load	[N]	*8	1500	1700	1900	2000	2100	2300	2400	2500
Maximum Radial Load	[N]	*9	4300							
Maximum Axial Load	[N]	*10	3900							
Moment of Inertia ($\leq \varnothing 14$)	[kgcm ²]	--	--	--	--	--	--	--	--	--
Moment of Inertia ($\leq \varnothing 19$)	[kgcm ²]	--	6.740	5.490	5.020	4.770	4.650	4.550	4.490	4.460
Moment of Inertia ($\leq \varnothing 28$)	[kgcm ²]	--	8.340	7.080	6.610	6.360	6.240	6.140	6.080	6.050
Moment of Inertia ($\leq \varnothing 38$)	[kgcm ²]	--	15.410	14.150	13.690	13.430	13.310	13.220	13.160	13.120
Efficiency	[%]	*11	93							
Torsional Rigidity	[Nm/arc-min]	*12	31							
Maximum Torsional Backlash	[arc-min]	--	≤ 6							
Noise Level	[dB]	*13	85							
Protection Class	--	*14	IP54 (IP65)							
Ambient Temperature	[°C]	--	0-40							
Permitted Housing Temperature	[°C]	--	90							
Weight	[kg]	*15	10.2							

EVL-120 – 3-Stage Specifications

Frame Size	120									
Stage	3-Stage									
Ratio	Unit	Note	15	16	20	25	28	30	35	40
Nominal Output Torque	[Nm]	*1	110	130	150	150	150	110	150	150
Maximum Acceleration Torque	[Nm]	*2	200	260	300	300	300	200	300	300
Emergency Stop Torque	[Nm]	*3	450	550	550	550	550	450	550	550
Nominal Input Speed	[rpm]	*4	3000							
Maximum Input Speed	[rpm]	*5	6000							
No Load Running Torque	[Nm]	*6	1.11							
Permitted Radial Load	[N]	*7	2300	2300	2500	2700	2800	2900	3000	3200
Permitted Axial Load	[N]	*8	3000	3100	3400	3700	3900	3900	3900	3900
Maximum Radial Load	[N]	*9	4300							
Maximum Axial Load	[N]	*10	3900							
Moment of Inertia ($\leq \varnothing 14$)	[kgcm ²]	--	2.250	2.460	2.200	2.180	2.400	1.870	2.160	1.860
Moment of Inertia ($\leq \varnothing 19$)	[kgcm ²]	--	2.580	2.790	2.530	2.510	2.730	2.200	2.490	2.190
Moment of Inertia ($\leq \varnothing 28$)	[kgcm ²]	--	4.700	4.910	4.650	4.640	4.860	4.330	4.620	4.320
Moment of Inertia ($\leq \varnothing 38$)	[kgcm ²]	--	--	--	--	--	--	--	--	--
Efficiency	[%]	*11	88							
Torsional Rigidity	[Nm/arc-min]	*12	31							
Maximum Torsional Backlash	[arc-min]	--	≤ 9							
Noise Level	[dB]	*13	85							
Protection Class	--	*14	IP54 (IP65)							
Ambient Temperature	[°C]	--	0-40							
Permitted Housing Temperature	[°C]	--	90							
Weight	[kg]	*15	10							

EVL-120 – 3-Stage Specifications

Frame Size	120										
Stage	3-Stage										
Ratio	Unit	Note	45	50	60	70	80	90	100		
Nominal Output Torque	[Nm]	*1	110	150	150	150	150	110	110		
Maximum Acceleration Torque	[Nm]	*2	200	300	300	300	300	200	200		
Emergency Stop Torque	[Nm]	*3	450	550	550	550	550	450	450		
Nominal Input Speed	[rpm]	*4	3000								
Maximum Input Speed	[rpm]	*5	6000								
No Load Running Torque	[Nm]	*6	1.11								
Permitted Radial Load	[N]	*7	3300	3400	3600	3800	4000	4200	4300		
Permitted Axial Load	[N]	*8	3900	3900	3900	3900	3900	3900	3900		
Maximum Radial Load	[N]	*9	4300								
Maximum Axial Load	[N]	*10	3900								
Moment of Inertia ($\leq \varnothing 14$)	[kgcm ²]	--	2.150	1.860	1.850	1.850	1.850	1.850	1.850		
Moment of Inertia ($\leq \varnothing 19$)	[kgcm ²]	--	2.480	2.190	2.180	2.180	2.180	2.180	2.180		
Moment of Inertia ($\leq \varnothing 28$)	[kgcm ²]	--	4.610	4.310	4.310	4.310	4.310	4.310	4.310		
Moment of Inertia ($\leq \varnothing 38$)	[kgcm ²]	--	--	--	--	--	--	--	--		
Efficiency	[%]	*11	88								
Torsional Rigidity	[Nm/arc-min]	*12	31								
Maximum Torsional Backlash	[arc-min]	--	≤ 9								
Noise Level	[dB]	*13	85								
Protection Class	--	*14	IP54 (IP65)								
Ambient Temperature	[°C]	--	0-40								
Permitted Housing Temperature	[°C]	--	90								
Weight	[kg]	*15	10								

- *1) At nominal input speed, service life is 20,000 hours
- *2) The maximum torque when starting or stopping operation
- *3) The maximum torque allowed under a stress situation (Permitted 1,000 times during service life)
- *4) The average input speed
- *5) The maximum intermittent input speed
- *6) This is the torque at no load applied on the input shaft. The input speed is 3000 rpm for EVL120
- *7) At this load and nominal input speed, service life will be 20,000 hours. (The radial load applied to the output side bearing)
- *8) At this load and nominal input speed, service life will be 20,000 hours. (The axial load applied to the output shaft center)
- *9) The maximum radial load that the reducer can accept
- *10) The maximum axial load that the reducer can accept
- *11) The efficiency at the nominal torque rating
- *12) This does not include the lost motion
- *13) Contact NIDEC-SHIMPO for the testing conditions and environment
- *14) IP65 (wash-down) is available as an option. Contact NIDEC-SHIMPO for more details and our food grade options
- *15) The weight may vary slightly between models

EVL-SERIES Right-angle shaft

EVL-120 – 2-Stage Dimensions

Input shaft bore $\leq \varnothing 19$

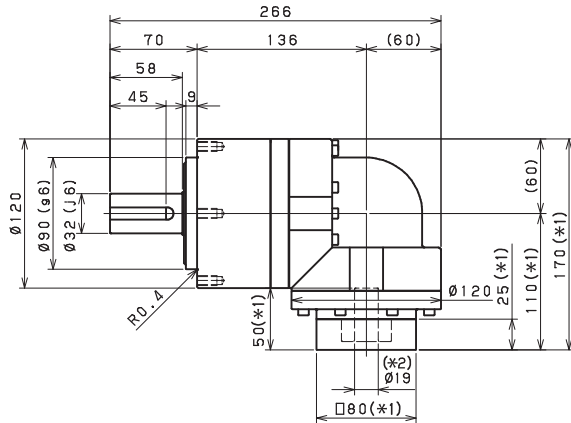
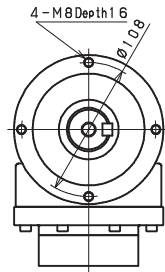

Input shaft bore $\leq \varnothing 28$

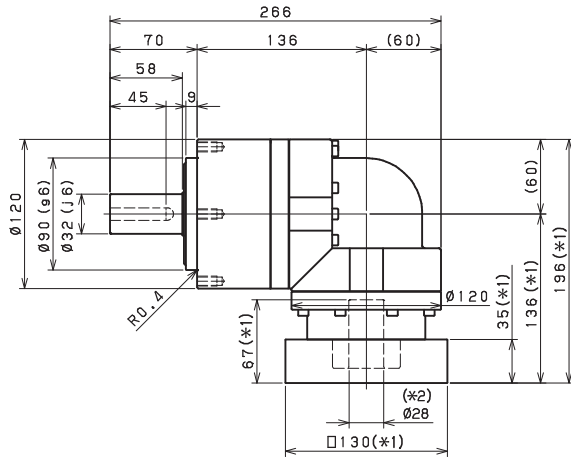
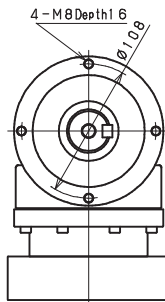

Input shaft bore $\leq \varnothing 38$

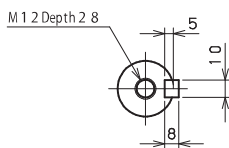
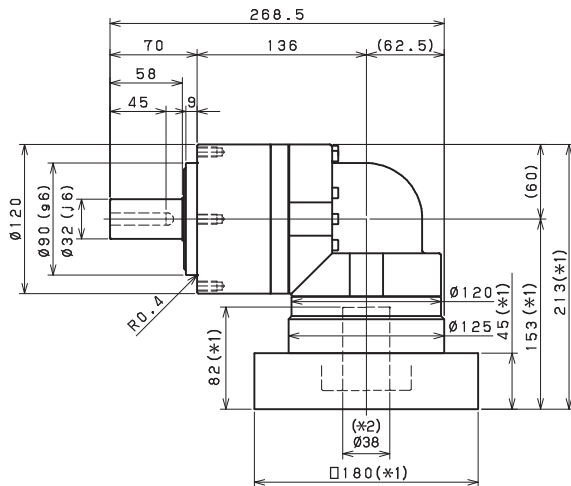
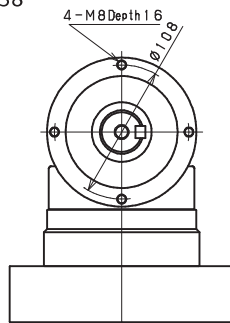

Shaft with key

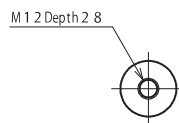

Smooth shaft

- *1) Length will vary depending on motor
- *2) Bushing will be inserted to adapt to motor shaft

EVL-120 – 3-Stage Dimensions

Input shaft bore $\leq \varnothing 14$

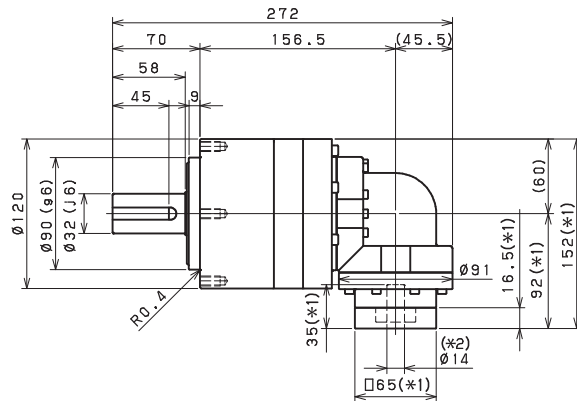
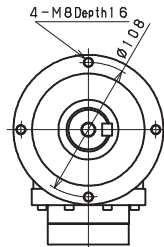

Input shaft bore $\leq \varnothing 19$

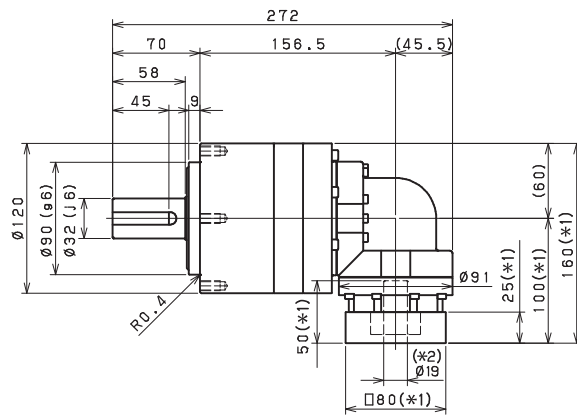
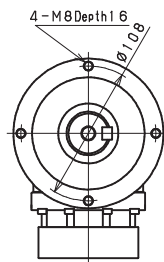

Input shaft bore $\leq \varnothing 28$

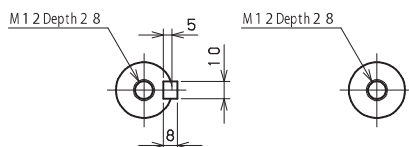
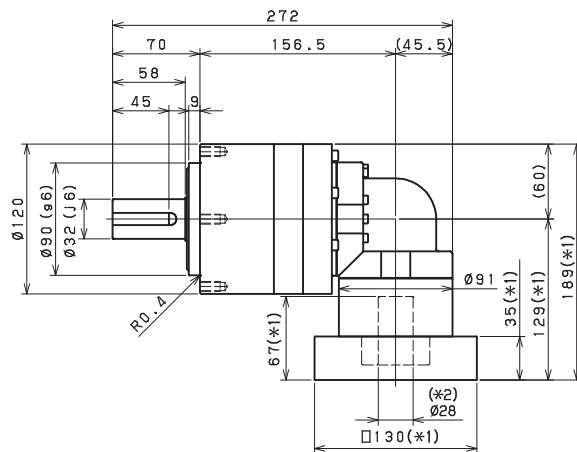
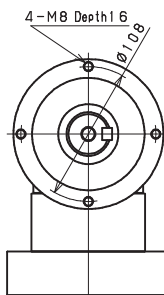

Shaft with key

Smooth shaft

*1) Length will vary depending on motor

*2) Bushing will be inserted to adapt to motor shaft

EVL-SERIES Right-angle shaft

EVL-120 – 2-Stage Adapter Dimensions

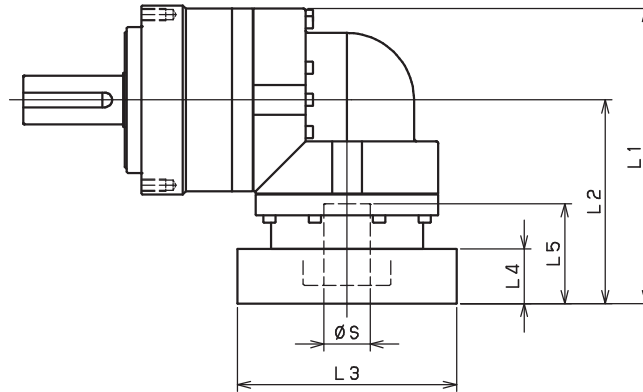

Model number	**: Adapter code	2-Stage				
		L1	L2	L3	L4	L5
EVL-120-□-□-14** (S ≤ 14)	BA•BB•BD•BE•BF•BG•BH•BJ•BK•BP	--	--	--	--	--
	BC•BH•BM•BN	--	--	--	--	--
	CA•CC	--	--	--	--	--
	DA•DB•DC•DD•DF•DH•DJ	--	--	--	--	--
	EA•EB•EC•EF•EG•EK•EL	--	--	--	--	--
	FA	--	--	--	--	--
	FB	--	--	--	--	--
EVL-120-□-□-19** (14 < S ≤ 19)	DA•DB•DC	170	110	□80	25	50
	EB•ED	170	110	□90	25	50
	FA	170	110	□100	25	50
	FB	180	120	□100	35	60
	GB•GD•GJ	170	110	□115	25	50
	HA	170	110	□130	25	50
	HB	185	125	□130	40	65
EVL-120-□-□-28** (19 < S ≤ 28)	JA	180	120	□150	35	60
	FA•FB•FC	196	136	□100	35	67
	FD•FE	191	131	□100	30	62
	GA•GB•GC•GD•GE•GF•GG•GH	196	136	□115	35	67
	HA•HC•HD	196	136	□130	35	67
	HB	206	146	□130	45	77
	HE	211	151	□130	50	82
	HF	191	131	□130	30	62
	JA•JB•JC•JF	196	136	□150	35	67
	JD	216	156	□150	55	87
EVL-120-□-□-38** (28 < S ≤ 38)	JE	206	146	□150	45	77
	KA•KB•KE	196	136	□180	35	67
	KD	206	146	□180	45	77
	HA	213	153	□130	45	82
	HB•HE	208	148	□130	40	77
	JA	213	153	□150	45	82
KA•KB•KC	213	153	□180	45	82	
KD	248	188	□180	80	117	
KE	228	168	□180	60	97	

*1) Double reduction : 1/3~ 1/10

*2) Bushing will be inserted to adapt to motor shaft

For an explanation on the Adapter Flange Code, please turn to page 422.

A more comprehensive adapter flange offering can be found using the NIDEC-SHIMPO Online Selector Tool. The variety is constantly expanding and being updated on the Selector Tool. If you have any questions or need any support, contact NIDEC-SHIMPO.

EVL-120 – 3-Stage Adapter Dimensions

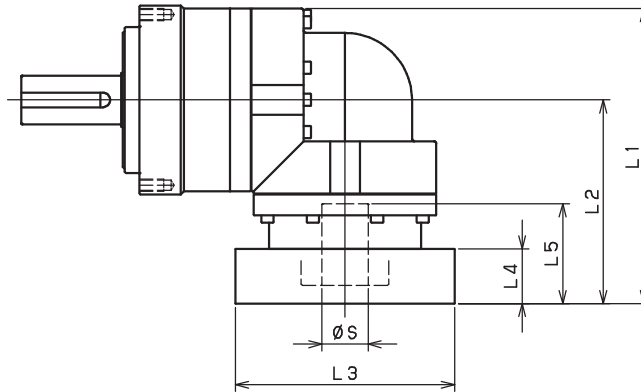

Model number	**: Adapter code	3-Stage				
		L1	L2	L3	L4	L5
EVL-120-□-□-14** (S ≤ 14)	BA•BB•BD•BE•BF•BG•BH•BJ•BK•BP	152	92	□65	16.5	35
	BC•BH•BM•BN	157	97	□65	21.5	40
	CA•CC	152	92	□70	16.5	35
	DA•DB•DC•DD•DF•DH•DJ	152	92	□80	16.5	35
	EA•EB•EC•EF•EG•EK•EL	152	92	□90	16.5	35
	FA	152	92	□100	16.5	35
	FB	162	102	□100	26.5	45
EVL-120-□-□-19** (14 < S ≤ 19)	DA•DB•DC	160	100	□80	25	50
	EB•ED	160	100	□90	25	50
	FA	160	100	□100	25	50
	FB	170	110	□100	35	60
	GB•GD•GJ	160	100	□115	25	50
	HA	160	100	□130	25	50
	HB	175	115	□130	40	65
EVL-120-□-□-28** (19 < S ≤ 28)	JA	170	110	□150	35	60
	FA•FB•FC	189	129	□100	35	67
	FD•FE	184	124	□100	30	62
	GA•GB•GC•GD•GE•GF•GG•GH	189	129	□115	35	67
	HA•HC•HD	189	129	□130	35	67
	HB	199	139	□130	45	77
	HE	204	144	□130	50	82
	HF	184	124	□130	30	62
	JA•JB•JC•JF	189	129	□150	35	67
	JD	209	149	□150	55	87
EVL-120-□-□-38** (28 < S ≤ 38)	JE	199	139	□150	45	77
	KA•KB•KE	189	129	□180	35	67
	KD	199	139	□180	45	77
	HA	--	--	--	--	--
	HB•HE	--	--	--	--	--
	JA	--	--	--	--	--
KA•KB•KC	--	--	--	--	--	
KD	--	--	--	--	--	
KE	--	--	--	--	--	

*1) Triple reduction : 1/15~ 1/100

*2) Bushing will be inserted to adapt to motor shaft

For an explanation on the Adapter Flange Code, please turn to page 422.

A more comprehensive adapter flange offering can be found using the NIDEC-SHIMPO Online Selector Tool. The variety is constantly expanding and being updated on the Selector Tool. If you have any questions or need any support, contact NIDEC-SHIMPO.

EVL-SERIES Right-angle shaft

EVL-155 – 2-Stage Specifications

Frame Size	155											
Stage	2-Stage											
Ratio	Unit	Note	3	4	5	6	7	8	9	10		
Nominal Output Torque	[Nm]	*1	130	170	200	260	300	300	200	200		
Maximum Acceleration Torque	[Nm]	*2	260	340	400	520	600	600	400	400		
Emergency Stop Torque	[Nm]	*3	700	950	1100	1100	1100	1100	750	750		
Nominal Input Speed	[rpm]	*4	2000									
Maximum Input Speed	[rpm]	*5	4000									
No Load Running Torque	[Nm]	*6	3.26									
Permitted Radial Load	[N]	*7	3200	3500	3800	4000	4200	4400	4600	4700		
Permitted Axial Load	[N]	*8	2400	2700	3000	3300	3500	3700	3900	4100		
Maximum Radial Load	[N]	*9	9100									
Maximum Axial Load	[N]	*10	8200									
Moment of Inertia ($\leq \varnothing 19$)	[kgcm ²]	--	--	--	--	--	--	--	--	--		
Moment of Inertia ($\leq \varnothing 28$)	[kgcm ²]	--	23.130	18.570	16.910	16.010	15.580	15.230	14.770	14.660		
Moment of Inertia ($\leq \varnothing 38$)	[kgcm ²]	--	27.500	22.940	21.280	20.380	19.950	19.610	19.410	19.030		
Moment of Inertia ($\leq \varnothing 48$)	[kgcm ²]	--	40.730	36.170	34.510	33.610	33.180	32.840	32.370	32.260		
Efficiency	[%]	*11	93									
Torsional Rigidity	[Nm/arc-min]	*12	60									
Maximum Torsional Backlash	[arc-min]	--	≤ 6									
Noise Level	[dB]	*13	85									
Protection Class	--	*14	IP54 (IP65)									
Ambient Temperature	[°C]	--	0-40									
Permitted Housing Temperature	[°C]	--	90									
Weight	[kg]	*15	19.8									

EVL-155 – 3-Stage Specifications

Frame Size	155											
Stage	3-Stage											
Ratio	Unit	Note	15	16	20	25	28	30	35	40		
Nominal Output Torque	[Nm]	*1	200	300	300	300	300	200	300	300		
Maximum Acceleration Torque	[Nm]	*2	400	600	600	600	600	400	600	600		
Emergency Stop Torque	[Nm]	*3	750	1100	1100	1100	1100	750	1100	1100		
Nominal Input Speed	[rpm]	*4	2000									
Maximum Input Speed	[rpm]	*5	4000									
No Load Running Torque	[Nm]	*6	2.56									
Permitted Radial Load	[N]	*7	5400	5500	6000	6400	6700	6800	7200	7500		
Permitted Axial Load	[N]	*8	4900	5000	5500	6100	6400	6600	7000	7500		
Maximum Radial Load	[N]	*9	9100									
Maximum Axial Load	[N]	*10	8200									
Moment of Inertia ($\leq \varnothing 19$)	[kgcm ²]	--	6.400	7.290	6.220	6.150	7.090	4.990	6.090	4.950		
Moment of Inertia ($\leq \varnothing 28$)	[kgcm ²]	--	8.000	8.880	7.810	7.750	8.680	6.580	7.690	6.540		
Moment of Inertia ($\leq \varnothing 38$)	[kgcm ²]	--	15.070	15.960	14.890	14.820	15.760	13.660	14.760	13.610		
Moment of Inertia ($\leq \varnothing 48$)	[kgcm ²]	--	--	--	--	--	--	--	--	--		
Efficiency	[%]	*11	88									
Torsional Rigidity	[Nm/arc-min]	*12	60									
Maximum Torsional Backlash	[arc-min]	--	≤ 9									
Noise Level	[dB]	*13	85									
Protection Class	--	*14	IP54 (IP65)									
Ambient Temperature	[°C]	--	0-40									
Permitted Housing Temperature	[°C]	--	90									
Weight	[kg]	*15	20.4									

EVL-155 – 3-Stage Specifications

Frame Size	155										
Stage	3-Stage										
Ratio	Unit	Note	45	50	60	70	80	90	100		
Nominal Output Torque	[Nm]	*1	200	300	300	300	300	200	200		
Maximum Acceleration Torque	[Nm]	*2	400	600	600	600	600	400	400		
Emergency Stop Torque	[Nm]	*3	750	1100	1100	1100	1100	750	750		
Nominal Input Speed	[rpm]	*4	2000								
Maximum Input Speed	[rpm]	*5	4000								
No Load Running Torque	[Nm]	*6	2.56								
Permitted Radial Load	[N]	*7	7800	8100	8600	9100	9100	9100	9100		
Permitted Axial Load	[N]	*8	7900	8200	8200	8200	8200	8200	8200		
Maximum Radial Load	[N]	*9	9100								
Maximum Axial Load	[N]	*10	8200								
Moment of Inertia (≤ Ø 19)	[kgcm ²]	--	6.070	4.930	4.920	4.910	4.910	4.910	4.910		
Moment of Inertia (≤ Ø 28)	[kgcm ²]	--	7.660	6.520	6.510	6.510	6.500	6.500	6.500		
Moment of Inertia (≤ Ø 38)	[kgcm ²]	--	14.740	13.590	13.590	13.580	13.580	13.570	13.570		
Moment of Inertia (≤ Ø 48)	[kgcm ²]	--	--	--	--	--	--	--	--		
Efficiency	[%]	*11	88								
Torsional Rigidity	[Nm/arc-min]	*12	60								
Maximum Torsional Backlash	[arc-min]	--	≤ 9								
Noise Level	[dB]	*13	85								
Protection Class	--	*14	IP54 (IP65)								
Ambient Temperature	[°C]	--	0-40								
Permitted Housing Temperature	[°C]	--	90								
Weight	[kg]	*15	20.4								

- *1) At nominal input speed, service life is 20,000 hours
- *2) The maximum torque when starting or stopping operation
- *3) The maximum torque allowed under a stress situation (Permitted 1,000 times during service life)
- *4) The average input speed
- *5) The maximum intermittent input speed
- *6) This is the torque at no load applied on the input shaft. The input speed is 2000 rpm for EVL155
- *7) At this load and nominal input speed, service life will be 20,000 hours. (The radial load applied to the output side bearing)
- *8) At this load and nominal input speed, service life will be 20,000 hours. (The axial load applied to the output shaft center)
- *9) The maximum radial load that the reducer can accept
- *10) The maximum axial load that the reducer can accept
- *11) The efficiency at the nominal torque rating
- *12) This does not include the lost motion
- *13) Contact NIDEC-SHIMPO for the testing conditions and environment
- *14) IP65 (wash-down) is available as an option. Contact NIDEC-SHIMPO for more details and our food grade options
- *15) The weight may vary slightly between models

EVL-SERIES Right-angle shaft

EVL-155 – 2-Stage Dimensions

Input shaft bore $\leq \varnothing 28$

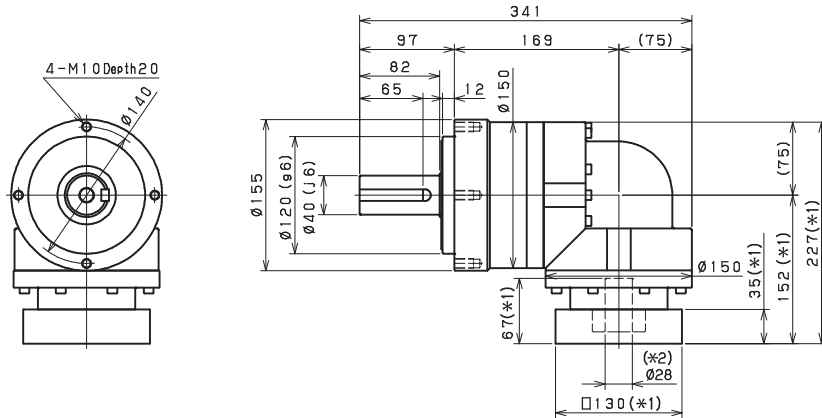

Input shaft bore $\leq \varnothing 38$

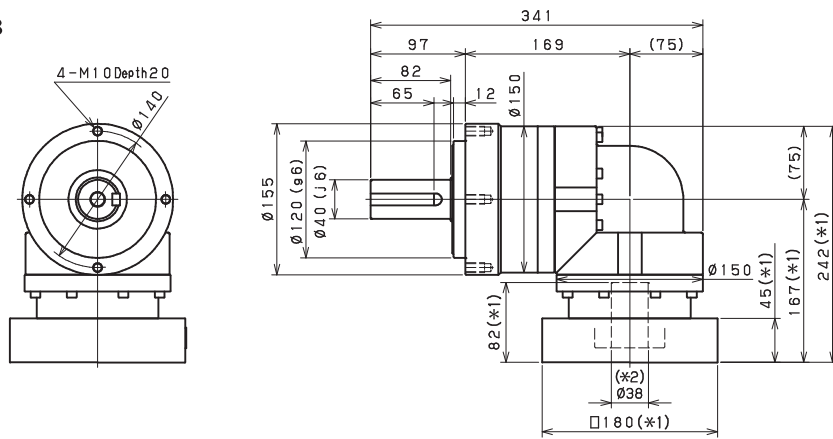

Input shaft bore $\leq \varnothing 48$

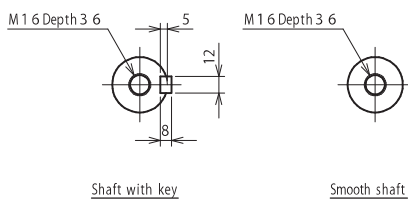
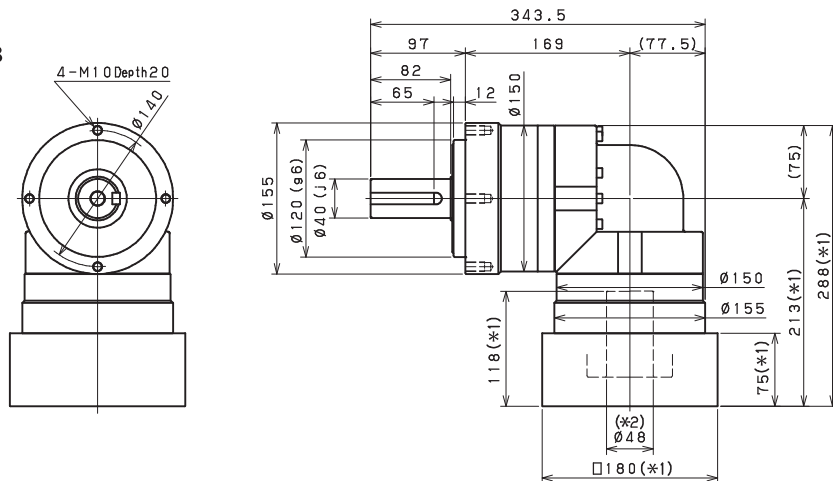

- *1) Length will vary depending on motor.
- *2) Bushing will be inserted to adapt to motor shaft

EVL-155 – 3-Stage Dimensions

Input shaft bore $\cong \varnothing 19$

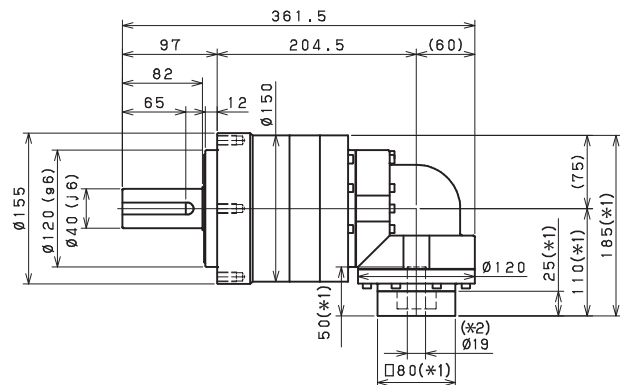
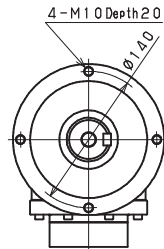

Input shaft bore $\cong \varnothing 28$

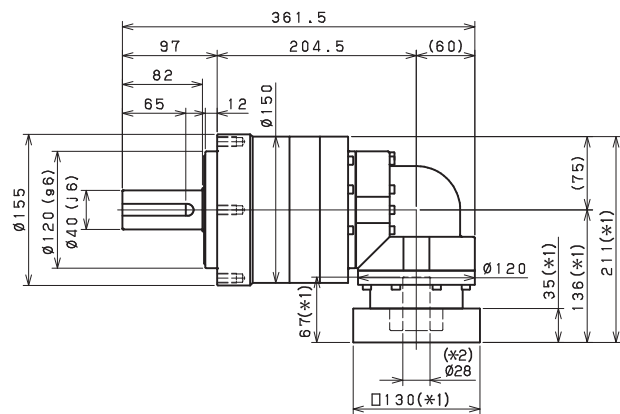
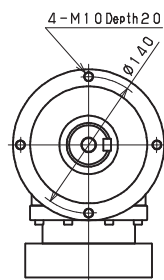

Input shaft bore $\cong \varnothing 38$

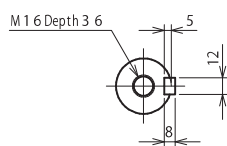
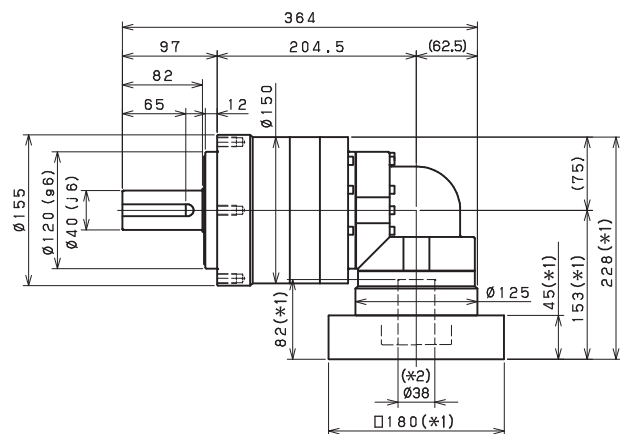
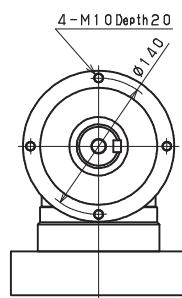

Shaft with key

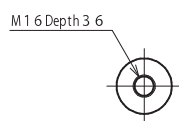

Smooth shaft

*1) Length will vary depending on motor.

*2) Bushing will be inserted to adapt to motor shaft

EVL-SERIES Right-angle shaft

EVL-155 – 2-Stage Adapter Dimensions

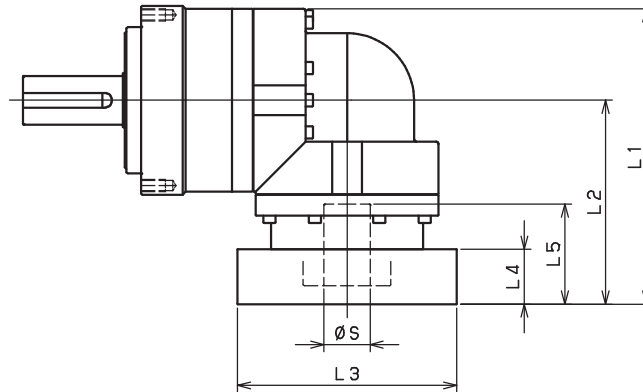

Model number	**: Adapter code	2-Stage				
		L1	L2	L3	L4	L5
EVL-155-□-□-19** (S≤19)	DA•DB•DC	--	--	--	--	--
	EB•ED	--	--	--	--	--
	FA	--	--	--	--	--
	FB	--	--	--	--	--
	GB•GD•GJ	--	--	--	--	--
	HA	--	--	--	--	--
	HB	--	--	--	--	--
EVL-155-□-□-28** (19< S≤28)	FA•FB•FC	229.5	152	□100	35	67
	GA•GB•GC•GD•GE•GF•GG•GH	229.5	152	□115	35	67
	HA•HC•HD	229.5	152	□130	35	67
	HB	239.5	162	□130	45	77
	HF	224.5	147	□130	30	62
	JA•JB•JC•JF	229.5	152	□150	35	67
	KA•KB•KE	229.5	152	□180	35	67
	LA	229.5	152	□200	35	67
	LB	239.5	162	□200	45	77
	MA	229.5	152	□220	35	67
	MB	239.5	162	□220	45	77
EVL-155-□-□-38** (28< S≤38)	HA	244.5	167	□130	45	82
	HB•HE	239.5	162	□130	40	77
	JA	244.5	167	□150	45	82
	KA•KB•KC	244.5	167	□180	45	82
	KD	279.5	202	□180	80	117
	KE	259.5	182	□180	60	97
	LB	254.5	177	□200	55	92
	MA•MB	244.5	167	□220	45	82
	MC	259.5	182	□220	60	97
MD	254.5	177	□220	55	92	
EVL-155-□-□-48** (38< S≤48)	KA	290.5	213	□180	75	118
	KB•KC	270.5	193	□180	55	98
	LA	270.5	193	□200	55	98
	MA	270.5	193	□220	55	98
	MB	290.5	213	□220	75	118

*1) Double reduction : 1/3~ 1/10

*2) Bushing will be inserted to adapt to motor shaft

For an explanation on the Adapter Flange Code, please turn to page 422.

A more comprehensive adapter flange offering can be found using the NIDEC-SHIMPO Online Selector Tool. The variety is constantly expanding and being updated on the Selector Tool. If you have any questions or need any support, contact NIDEC-SHIMPO.

EVL-155 – 3-Stage Adapter Dimensions

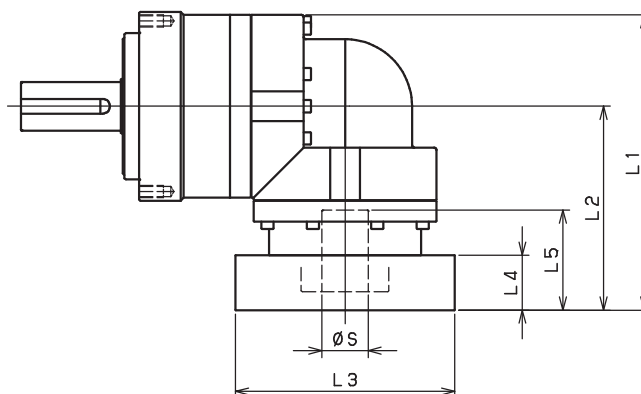

Model number	**: Adapter code	3-Stage				
		L1	L2	L3	L4	L5
EVL-155-□-□-19** (S≤19)	DA•DB•DC	187.5	110	□80	25	50
	EB•ED	187.5	110	□90	25	50
	FA	187.5	110	□100	25	50
	FB	197.5	120	□100	35	60
	GB•GD•GJ	187.5	110	□115	25	50
	HA	187.5	110	□130	25	50
	HB	202.5	125	□130	40	65
	JA	197.5	120	□150	35	60
EVL-155-□-□-28** (19< S≤28)	FA•FB•FC	213.5	136	□100	35	67
	GA•GB•GC•GD•GE•GF•GG•GH	213.5	136	□115	35	67
	HA•HC•HD	213.5	136	□130	35	67
	HB	223.5	146	□130	45	77
	HF	208.5	131	□130	30	62
	JA•JB•JC•JF	213.5	136	□150	35	67
	KA•KB•KE	213.5	136	□180	35	67
	LA	213.5	136	□200	35	67
	LB	223.5	146	□200	45	77
	MA	213.5	136	□220	35	67
	MB	223.5	146	□220	45	77
EVL-155-□-□-38** (28< S≤38)	HA	230.5	153	□130	45	82
	HB•HE	225.5	148	□130	40	77
	JA	230.5	153	□150	45	82
	KA•KB•KC	230.5	153	□180	45	82
	KD	265.5	188	□180	80	117
	KE	245.5	168	□180	60	97
	LB	240.5	163	□200	55	92
	MA•MB	230.5	153	□220	45	82
	MC	245.5	168	□220	60	97
MD	240.5	163	□220	55	92	
EVL-155-□-□-48** (38< S≤48)	KA	--	--	--	--	--
	KB•KC	--	--	--	--	--
	LA	--	--	--	--	--
	MA	--	--	--	--	--
	MB	--	--	--	--	--

*1) Triple reduction : 1/15~ 1/100

*2) Bushing will be inserted to adapt to motor shaft

For an explanation on the Adapter Flange Code, please turn to page 422.

A more comprehensive adapter flange offering can be found using the NIDEC-SHIMPO Online Selector Tool. The variety is constantly expanding and being updated on the Selector Tool. If you have any questions or need any support, contact NIDEC-SHIMPO.

EVL-SERIES Right-angle shaft

EVL-205 – 2-Stage Specifications

Frame Size	205									
Stage	2-Stage									
Ratio	Units	Note	3	4	5	6	7	8	9	10
Nominal Output Torque	[Nm]	*1	400	575	600	600	600	600	400	400
Maximum Acceleration Torque	[Nm]	*2	575	770	960	1120	1120	1120	775	775
Emergency Stop Torque	[Nm]	*3	1300	1700	2000	2500	2500	2500	2000	2000
Nominal Input Speed	[rpm]	*4	1500							
Maximum Input Speed	[rpm]	*5	3000							
No Load Running Torque	[Nm]	*6	10.8							
Permitted Radial Load	[N]	*7	5600	6200	6700	7100	7400	7800	8100	8400
Permitted Axial Load	[N]	*8	4300	4900	5400	5800	6300	6600	7000	7300
Maximum Radial Load	[N]	*9	15000							
Maximum Axial Load	[N]	*10	14000							
Moment of Inertia ($\leq \varnothing 28$)	[kgcm ²]	--	--	--	--	--	--	--	--	--
Moment of Inertia ($\leq \varnothing 38$)	[kgcm ²]	--	93.71	77.72	71.89	68.74	66.43	65.27	64.60	64.28
Moment of Inertia ($\leq \varnothing 48$)	[kgcm ²]	--	128.6	112.6	106.8	103.6	101.3	100.1	99.46	99.14
Moment of Inertia ($\leq \varnothing 65$)	[kgcm ²]	--	214.2	198.2	192.4	189.2	186.9	185.7	185.1	184.7
Efficiency	[%]	*11	93							
Torsional Rigidity	[Nm/arcmin]	*12	175							
Maximum Torsional Backlash	[Arc-min]	--	≤ 8							
Noise Level	[dB]	*13	≤ 85							
Protection Class	--	*14	IP54 (IP65)							
Ambient Temperature	[°C]	--	0-40							
Permitted Housing Temperature	[°C]	--	90							
Weight	[kg]	*15	52							

EVL-205 – 3-Stage Specifications

Frame Size	205									
Stage	3-Stage									
Ratio	Units	Note	15	16	20	25	28	30	35	40
Nominal Output Torque	[Nm]	*1	400	555	600	600	600	400	600	600
Maximum Acceleration Torque	[Nm]	*2	775	1120	1120	1120	1120	775	1120	1120
Emergency Stop Torque	[Nm]	*3	2000	2500	2500	2500	2500	2000	2500	2500
Nominal Input Speed	[rpm]	*4	1500							
Maximum Input Speed	[rpm]	*5	3000							
No Load Running Torque	[Nm]	*6	4.7							
Permitted Radial Load	[N]	*7	9600	9800	11000	11000	12000	12000	13000	13000
Permitted Axial Load	[N]	*8	8700	8900	9900	11000	11000	12000	13000	13000
Maximum Radial Load	[N]	*9	15000							
Maximum Axial Load	[N]	*10	14000							
Moment of Inertia ($\leq \varnothing 28$)	[kgcm ²]	--	11.49	12.09	11.15	10.98	11.59	10.33	10.83	10.24
Moment of Inertia ($\leq \varnothing 38$)	[kgcm ²]	--	20.28	20.88	19.94	19.77	20.38	19.11	19.62	19.03
Moment of Inertia ($\leq \varnothing 48$)	[kgcm ²]	--	25.10	25.70	24.76	24.59	25.20	23.94	24.44	23.85
Moment of Inertia ($\leq \varnothing 65$)	[kgcm ²]	--	--	--	--	--	--	--	--	--
Efficiency	[%]	*11	88							
Torsional Rigidity	[Nm/arcmin]	*12	175							
Maximum Torsional Backlash	[Arc-min]	--	≤ 11							
Noise Level	[dB]	*13	≤ 85							
Protection Class	--	*14	IP54 (IP65)							
Ambient Temperature	[°C]	--	0-40							
Permitted Housing Temperature	[°C]	--	90							
Weight	[kg]	*15	39							

EVL-205 – 3-Stage Specifications

Frame Size	205										
Stage	3-Stage										
Ratio	Units	Note	45	50	60	70	80	90	100		
Nominal Output Torque	[Nm]	*1	400	600	600	600	600	400	400		
Maximum Acceleration Torque	[Nm]	*2	775	1120	1120	1120	1120	775	775		
Emergency Stop Torque	[Nm]	*3	2000	2500	2500	2500	2500	2000	2000		
Nominal Input Speed	[rpm]	*4	1500								
Maximum Input Speed	[rpm]	*5	3000								
No Load Running Torque	[Nm]	*6	4.7								
Permitted Radial Load	[N]	*7	14000	14000	15000	15000	15000	15000	15000		
Permitted Axial Load	[N]	*8	14000	14000	14000	14000	14000	14000	14000		
Maximum Radial Load	[N]	*9	15000								
Maximum Axial Load	[N]	*10	14000								
Moment of Inertia (≤Ø 28)	[kgcm ²]	--	10.76	10.20	10.18	10.16	10.15	10.15	10.14		
Moment of Inertia (≤Ø 38)	[kgcm ²]	--	19.55	18.99	18.96	18.95	18.94	18.93	18.93		
Moment of Inertia (≤Ø 48)	[kgcm ²]	--	24.37	23.81	23.78	23.77	23.76	23.75	23.75		
Moment of Inertia (≤Ø 65)	[kgcm ²]	--	--	--	--	--	--	--	--		
Efficiency	[%]	*11	88								
Torsional Rigidity	[Nm/arcmin]	*12	175								
Maximum Torsional Backlash	[Arc-min]	--	≤ 11								
Noise Level	[dB]	*13	≤ 85								
Protection Class	--	*14	IP54 (IP65)								
Ambient Temperature	[°C]	--	0-40								
Permitted Housing Temperature	[°C]	--	90								
Weight	[kg]	*15	39								

- *1) At nominal input speed, service life is 20,000 hours
- *2) The maximum torque when starting or stopping operation
- *3) The maximum torque allowed under a stress situation (Permitted 1,000 times during service life)
- *4) The average input speed
- *5) The maximum intermittent input speed
- *6) This is the torque at no load applied on the input shaft. The input speed is 1500 rpm for EVL205
- *7) At this load and nominal input speed, service life will be 20,000 hours. (The radial load applied to the output side bearing)
- *8) At this load and nominal input speed, service life will be 20,000 hours. (The axial load applied to the output shaft center)
- *9) The maximum radial load that the reducer can accept
- *10) The maximum axial load that the reducer can accept
- *11) The efficiency at the nominal torque rating
- *12) This does not include the lost motion
- *13) Contact NIDEC-SHIMPO for the testing conditions and environment
- *14) IP65 (wash-down) is available as an option. Contact NIDEC-SHIMPO for more details and our food grade options
- *15) The weight may vary slightly between models

EVL-SERIES Right-angle shaft

EVL-205 – 2-Stage Dimensions

Input shaft bore $\leq \varnothing 38$

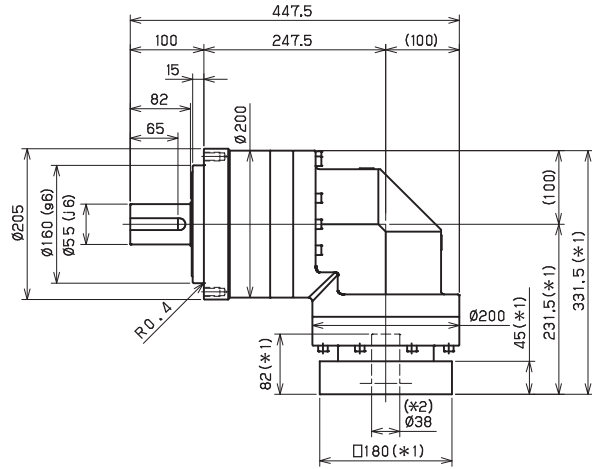
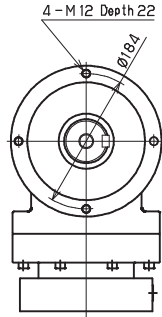

Input shaft bore $\leq \varnothing 48$

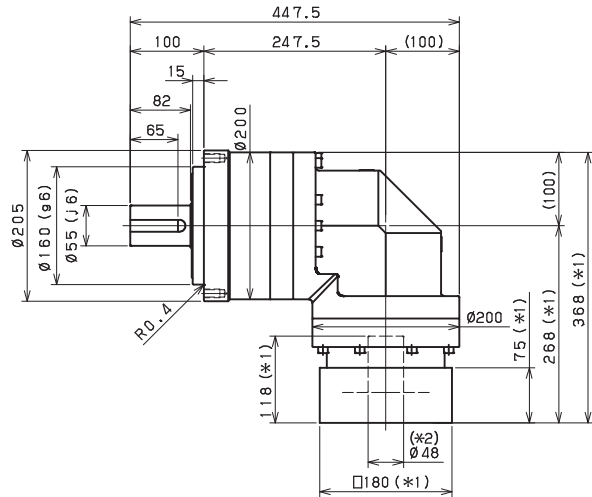
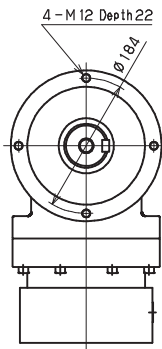

Input shaft bore $\leq \varnothing 65$

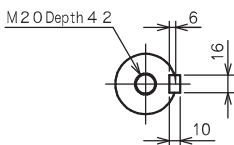
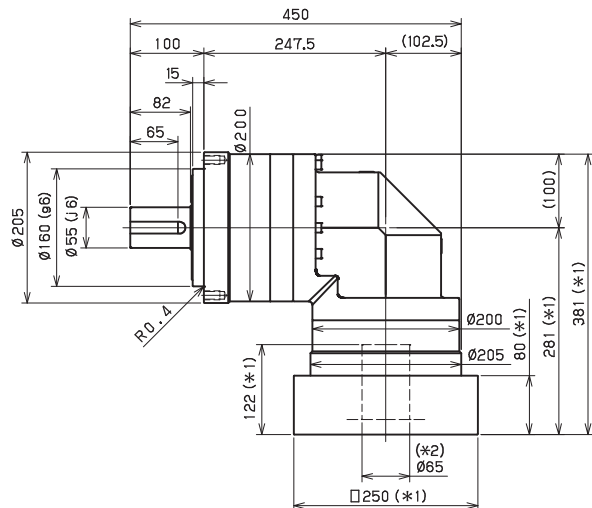
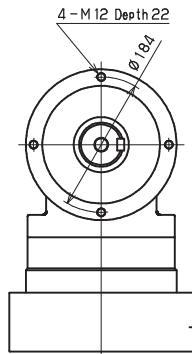

Shaft with key

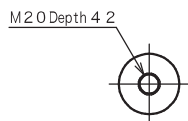

Smooth shaft

*1) Length will vary depending on motor.

*2) Bushing will be inserted to adapt to motor shaft

EVL-205 – 3-Stage Dimensions

Input shaft bore $\leq \varnothing 28$

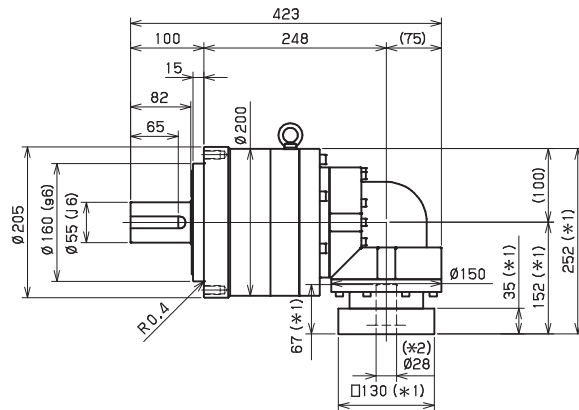
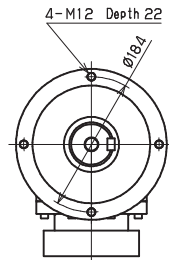

Input shaft bore $\leq \varnothing 38$

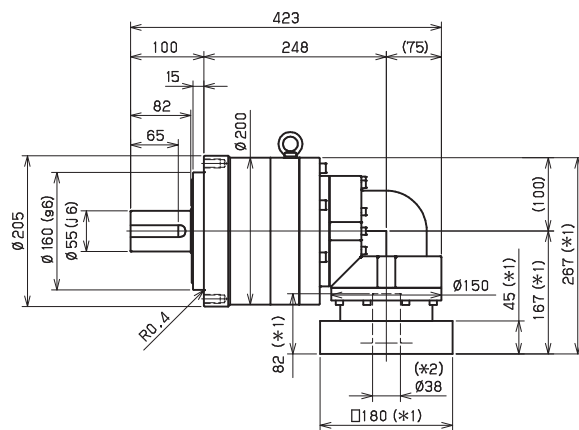
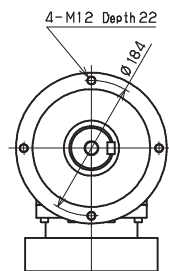

Input shaft bore $\leq \varnothing 48$

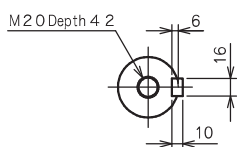
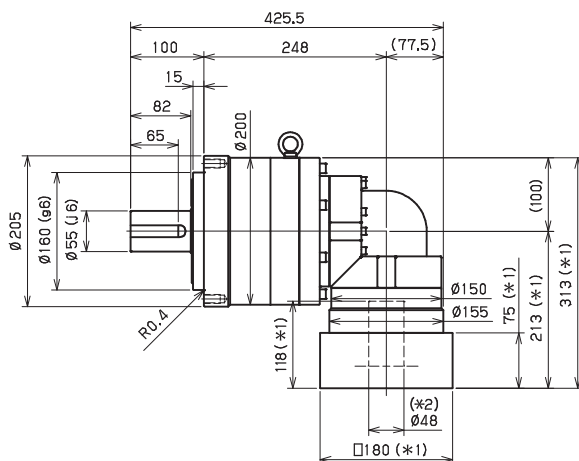
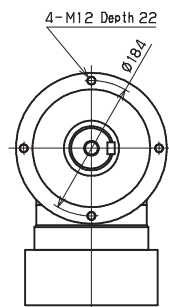

Shaft with key

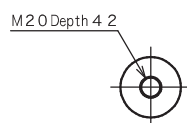

Smooth shaft

*1) Length will vary depending on motor.

*2) Bushing will be inserted to adapt to motor shaft

EVL-SERIES Right-angle shaft

EVL-205 – 2-Stage Adapter Dimensions

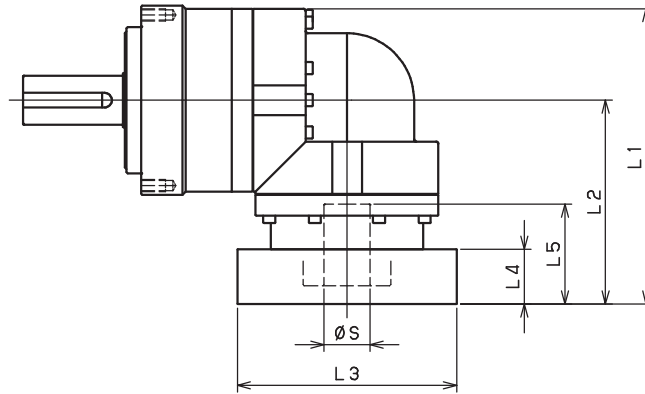

Model number	**: Adapter code	2-Stage				
		L1	L2	L3	L4	L5
EVL-205-□-□-28** (S ≤ 28)	FA·FB·FC	--	--	--	--	--
	GA·GB·GC·GD·GE·GF·GG·GH	--	--	--	--	--
	HA·HC·HD	--	--	--	--	--
	HB	--	--	--	--	--
	HF	--	--	--	--	--
	JA·JB·JC·JF	--	--	--	--	--
	KA·KB·KE	--	--	--	--	--
	LA	--	--	--	--	--
	LB	--	--	--	--	--
	MA	--	--	--	--	--
EVL-205-□-□-38** (28 < S ≤ 38)	HA	331.5	231.5	□130	45	82
	HB·HE	326.5	226.5	□130	40	77
	JA	331.5	231.5	□150	45	82
	KA·KB·KC	331.5	231.5	□180	45	82
	KD	366.5	266.5	□180	80	117
	KE	346.5	246.5	□180	60	97
	LA	331.5	231.5	□200	45	82
	LB	341.5	241.5	□200	55	92
	MA·MB	331.5	231.5	□220	45	82
	MC	346.5	246.5	□220	60	97
	MD	341.5	241.5	□220	55	92
NA	331.5	231.5	□250	45	82	
EVL-205-□-□-48** (38 < S ≤ 48)	KA	368	268	□180	75	118
	KB·KC	348	248	□180	55	98
	LA	348	248	□200	55	98
	MA	348	248	□220	55	98
	MB	368	268	□220	75	118
	NA	368	268	□250	75	118
	PA	368	268	□280	75	118
EVL-205-□-□-65** (48 < S ≤ 65)	MA·MB·MC·MD	381	281	□220	80	122
	NA·NC	381	281	□250	80	122
	NB·ND	411	311	□250	110	152
	PA	401	301	□280	100	142
	PB	411	311	□280	110	152

*1) Double reduction : 1/3 ~ 1/10

*2) Bushing will be inserted to adapt to motor shaft

For an explanation on the Adapter Flange Code, please turn to page 422.

A more comprehensive adapter flange offering can be found using the NIDEC-SHIMPO Online Selector Tool. The variety is constantly expanding and being updated on the Selector Tool. If you have any questions or need any support, contact NIDEC-SHIMPO.

EVL-205 – 3-Stage Adapter Dimensions

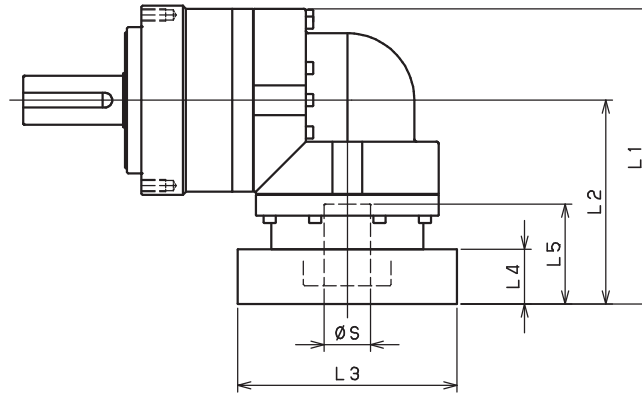

Model number	**: Adapter code	3-Stage				
		L1	L2	L3	L4	L5
EVL-205-□-□-28** (S ≤ 28)	FA·FB·FC	252	152	□100	35	67
	GA·GB·GC·GD·GE·GF·GG·GH	252	152	□115	35	67
	HA·HC·HD	252	152	□130	35	67
	HB	262	162	□130	45	77
	HF	247	147	□130	30	62
	JA·JB·JC·JF	252	152	□150	35	67
	KA·KB·KE	252	152	□180	35	67
	LA	252	152	□200	35	67
	LB	262	162	□200	45	77
	MA	252	152	□220	35	67
	MB	262	162	□220	45	77
EVL-205-□-□-38** (28 < S ≤ 38)	HA	267	167	□130	45	82
	HB·HE	262	162	□130	40	77
	JA	267	167	□150	45	82
	KA·KB·KC	267	167	□180	45	82
	KD	302	202	□180	80	117
	KE	282	182	□180	60	97
	LA	267	167	□200	45	82
	LB	277	177	□200	55	92
	MA·MB	267	167	□220	45	82
	MC	282	182	□220	60	97
	MD	277	177	□220	55	92
NA	267	167	□250	45	82	
EVL-205-□-□-48** (38 < S ≤ 48)	KA	313	213	□180	75	118
	KB·KC	293	193	□180	55	98
	LA	293	193	□200	55	98
	MA	293	193	□220	55	98
	MB	313	213	□220	75	118
	NA	313	213	□250	75	118
	PA	313	213	□280	75	118
EVL-205-□-□-65** (48 < S ≤ 65)	MA·MB·MC·MD	--	--	--	--	--
	NA·NC	--	--	--	--	--
	NB·ND	--	--	--	--	--
	PA	--	--	--	--	--
	PB	--	--	--	--	--

*1) Triple reduction : 1/15~ 1/100

*2) Bushing will be inserted to adapt to motor shaft

For an explanation on the Adapter Flange Code, please turn to page 422.

A more comprehensive adapter flange offering can be found using the NIDEC-SHIMPO Online Selector Tool. The variety is constantly expanding and being updated on the Selector Tool. If you have any questions or need any support, contact NIDEC-SHIMPO.

EVL-SERIES Right-angle shaft

EVL-235 – 2-Stage Specifications

Frame Size	235									
Stage	2-Stage									
Ratio	Units	Note	3	4	5	6	7	8	9	10
Nominal Output Torque	[Nm]	*1	575	765	960	1150	1200	1200	800	800
Maximum Acceleration Torque	[Nm]	*2	1015	1355	1695	1840	1840	1760	1520	1280
Emergency Stop Torque	[Nm]	*3	2500	3300	4000	4500	4500	4500	3600	3600
Nominal Input Speed	[rpm]	*4	1000							
Maximum Input Speed	[rpm]	*5	2000							
No Load Running Torque	[Nm]	*6	14.5							
Permitted Radial Load	[N]	*7	5800	6400	6900	7300	7700	8000	8400	8700
Permitted Axial Load	[N]	*8	6400	7200	7900	8600	9200	9700	10000	11000
Maximum Radial Load	[N]	*9	15000							
Maximum Axial Load	[N]	*10	14000							
Moment of Inertia ($\leq \varnothing 38$)	[kgcm ²]	--	--	--	--	--	--	--	--	--
Moment of Inertia ($\leq \varnothing 48$)	[kgcm ²]	--	148.00	122.90	113.30	108.10	104.70	102.70	101.60	101.00
Moment of Inertia ($\leq \varnothing 65$)	[kgcm ²]	--	223.20	198.10	188.60	183.30	180.00	178.00	176.80	176.20
Efficiency	[%]	*11	93							
Torsional Rigidity	[Nm/arcmin]	*12	400							
Maximum Torsional Backlash	[Arc-min]	--	≤ 8							
Noise Level	[dB]	*13	≤ 85							
Protection Class	--	*14	IP54 (IP65)							
Ambient Temperature	[°C]	--	0-40							
Permitted Housing Temperature	[°C]	--	90							
Weight	[kg]	*15	68							

EVL-235 – 3-Stage Specifications

Frame Size	235									
Stage	3-Stage									
Ratio	Units	Note	15	16	20	25	28	30	35	40
Nominal Output Torque	[Nm]	*1	800	1200	1200	1200	1200	800	1200	1200
Maximum Acceleration Torque	[Nm]	*2	1280	1840	1840	1840	1840	1280	1840	1840
Emergency Stop Torque	[Nm]	*3	3600	4500	4500	4500	4500	3600	4500	4500
Nominal Input Speed	[rpm]	*4	1000							
Maximum Input Speed	[rpm]	*5	2000							
No Load Running Torque	[Nm]	*6	10.2							
Permitted Radial Load	[N]	*7	9900	10000	11000	12000	12000	13000	13000	14000
Permitted Axial Load	[N]	*8	13000	13000	14000	14000	14000	14000	14000	14000
Maximum Radial Load	[N]	*9	15000							
Maximum Axial Load	[N]	*10	14000							
Moment of Inertia ($\leq \varnothing 38$)	[kgcm ²]	--	36.32	37.24	35.75	35.47	36.39	34.39	35.21	34.25
Moment of Inertia ($\leq \varnothing 48$)	[kgcm ²]	--	66.14	67.06	65.57	65.28	66.21	64.21	65.03	64.07
Moment of Inertia ($\leq \varnothing 65$)	[kgcm ²]	--	--	--	--	--	--	--	--	--
Efficiency	[%]	*11	88							
Torsional Rigidity	[Nm/arcmin]	*12	400							
Maximum Torsional Backlash	[Arc-min]	--	≤ 11							
Noise Level	[dB]	*13	≤ 85							
Protection Class	--	*14	IP54 (IP65)							
Ambient Temperature	[°C]	--	0-40							
Permitted Housing Temperature	[°C]	--	90							
Weight	[kg]	*15	70							

EVL-235 – 3-Stage Specifications

Frame Size	235										
Stage	3-Stage										
Ratio	Units	Note	45	50	60	70	80	90	100		
Nominal Output Torque	[Nm]	*1	800	1200	1200	1200	1200	800	800		
Maximum Acceleration Torque	[Nm]	*2	1040	1840	1840	1840	1440	1040	960		
Emergency Stop Torque	[Nm]	*3	3600	4500	4500	4500	4500	3600	3600		
Nominal Input Speed	[rpm]	*4	1000								
Maximum Input Speed	[rpm]	*5	2000								
No Load Running Torque	[Nm]	*6	10.2								
Permitted Radial Load	[N]	*7	14000	15000	15000	15000	15000	15000	15000		
Permitted Axial Load	[N]	*8	14000	14000	14000	14000	14000	14000	14000		
Maximum Radial Load	[N]	*9	15000								
Maximum Axial Load	[N]	*10	14000								
Moment of Inertia ($\leq \varnothing 38$)	[kgcm ²]	--	35.10	34.18	34.14	34.11	34.10	34.09	34.08		
Moment of Inertia ($\leq \varnothing 48$)	[kgcm ²]	--	64.92	63.99	63.95	63.93	63.91	63.90	63.90		
Moment of Inertia ($\leq \varnothing 65$)	[kgcm ²]	--	--	--	--	--	--	--	--		
Efficiency	[%]	*11	88								
Torsional Rigidity	[Nm/arcmin]	*12	400								
Maximum Torsional Backlash	[Arc-min]	--	≤ 11								
Noise Level	[dB]	*13	≤ 85								
Protection Class	--	*14	IP54 (IP65)								
Ambient Temperature	[°C]	--	0-40								
Permitted Housing Temperature	[°C]	--	90								
Weight	[kg]	*15	70								

*1) At nominal input speed, service life is 20,000 hours

*2) The maximum torque when starting or stopping operation

*3) The maximum torque allowed under a stress situation (Permitted 1,000 times during service life)

*4) The average input speed

*5) The maximum intermittent input speed

*6) This is the torque at no load applied on the input shaft. The input speed is 1000 rpm for EVL235

*7) At this load and nominal input speed, service life will be 20,000 hours. (The radial load applied to the output side bearing)

*8) At this load and nominal input speed, service life will be 20,000 hours. (The axial load applied to the output shaft center)

*9) The maximum radial load that the reducer can accept

*10) The maximum axial load that the reducer can accept

*11) The efficiency at the nominal torque rating

*12) This does not include the lost motion

*13) Contact NIDEC-SHIMPO for the testing conditions and environment

*14) IP65 (wash-down) is available as an option. Contact NIDEC-SHIMPO for more details and our food grade options

*15) The weight may vary slightly between models

EVL-SERIES Right-angle shaft

EVL-235 – 2-Stage Dimensions

Input shaft bore $\leq \phi 48$

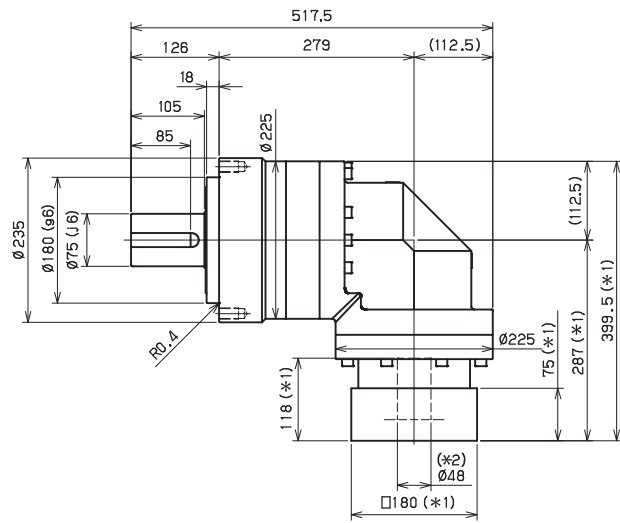
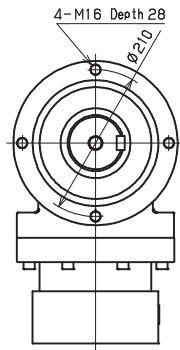

Input shaft bore $\leq \phi 65$

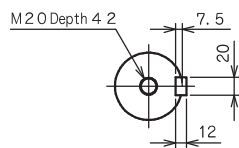
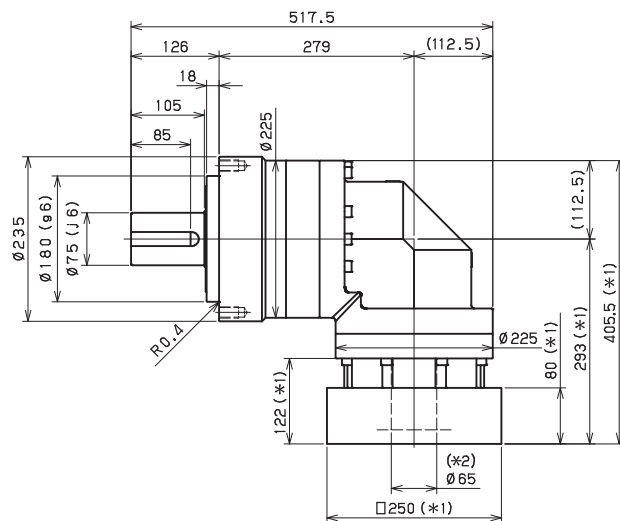
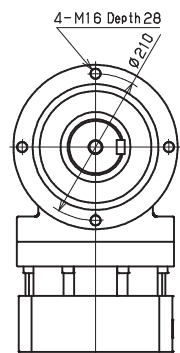

Shaft with key

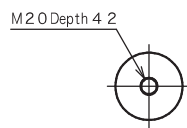

Smooth shaft

- *1) Length will vary depending on motor.
- *2) Bushing will be inserted to adapt to motor shaft

EVL-235 – 3-Stage Dimensions

Input shaft bore $\cong \phi 38$

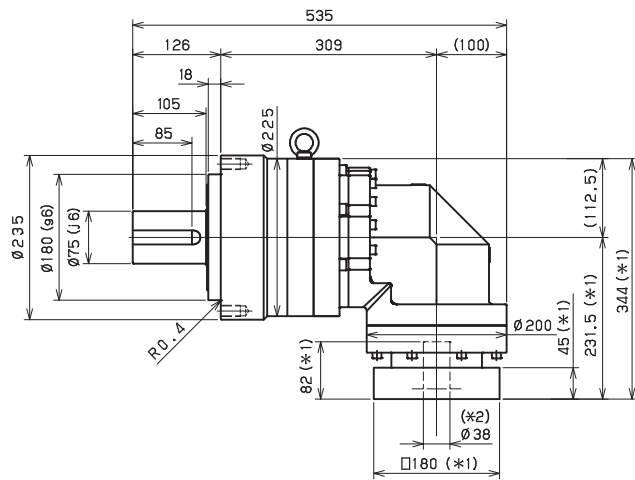
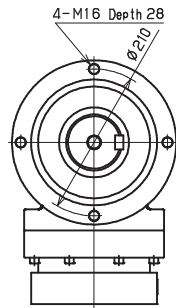

Input shaft bore $\cong \phi 48$

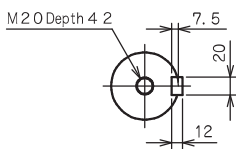
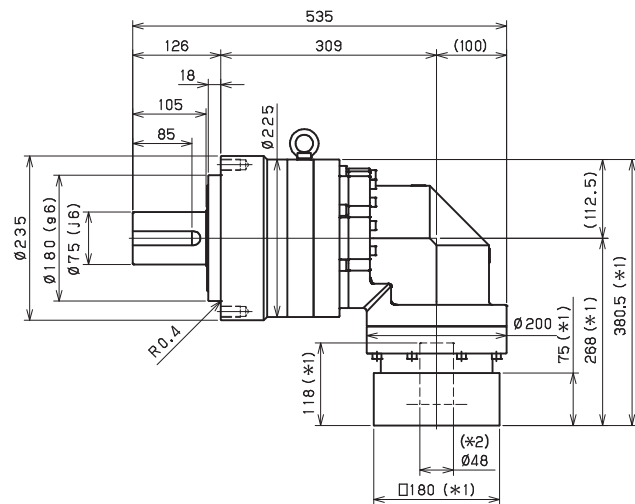
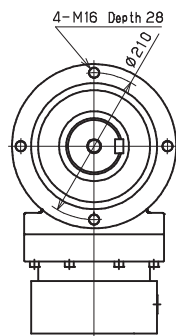

Shaft with key

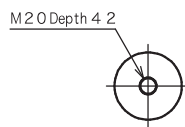

Smooth shaft

- *1) Length will vary depending on motor.
- *2) Bushing will be inserted to adapt to motor shaft

EVL-SERIES Right-angle shaft

EVL-235 – 2-Stage Adapter Dimensions

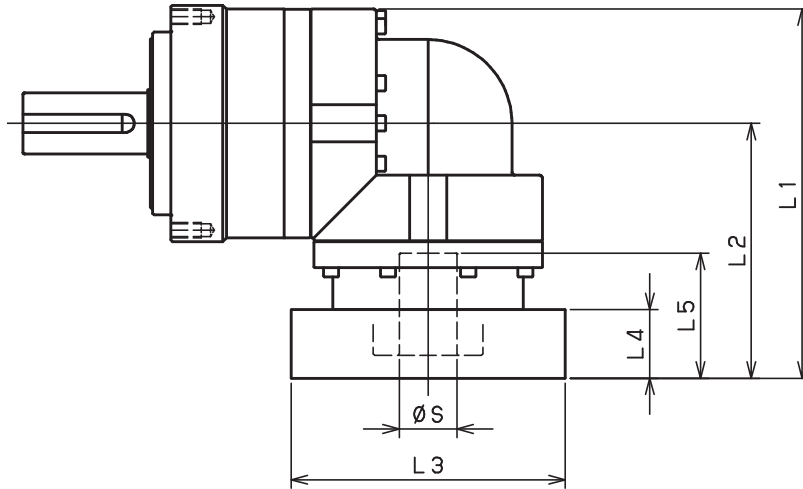

Model number	**: Adapter code	2-Stage				
		L1	L2	L3	L4	L5
EVL-235-□-□-38** (S ≤ 38)	HA	--	--	--	--	--
	HB-HE	--	--	--	--	--
	JA	--	--	--	--	--
	KA-KB-KC	--	--	--	--	--
	KD	--	--	--	--	--
	KE	--	--	--	--	--
	LA	--	--	--	--	--
	LB	--	--	--	--	--
	MA-MB	--	--	--	--	--
	MC	--	--	--	--	--
	MD	--	--	--	--	--
EVL-235-□-□-48** (38 < S ≤ 48)	KA	399.5	287	□180	75	118
	KB-KC	379.5	267	□180	55	98
	LA	379.5	267	□200	55	98
	MA	379.5	267	□220	55	98
	MB	399.5	287	□220	75	118
	NA	399.5	287	□250	75	118
	PA	399.5	287	□280	75	118
EVL-235-□-□-65** (48 < S ≤ 65)	MA-MB-MC-MD	405.5	293	□220	80	122
	NA-NC	405.5	293	□250	80	122
	NB-ND	435.5	323	□250	110	152
	PA	425.5	313	□280	100	142
	PB	435.5	323	□280	110	152
	QA-QB	425.5	313	□320	100	142

*1) Double reduction : 1/3~ 1/10

*2) Bushing will be inserted to adapt to motor shaft

For an explanation on the Adapter Flange Code, please turn to page 422.

A more comprehensive adapter flange offering can be found using the NIDEC-SHIMPO Online Selector Tool. The variety is constantly expanding and being updated on the Selector Tool. If you have any questions or need any support, contact NIDEC-SHIMPO.

EVL-235 – 3-Stage Adapter Dimensions

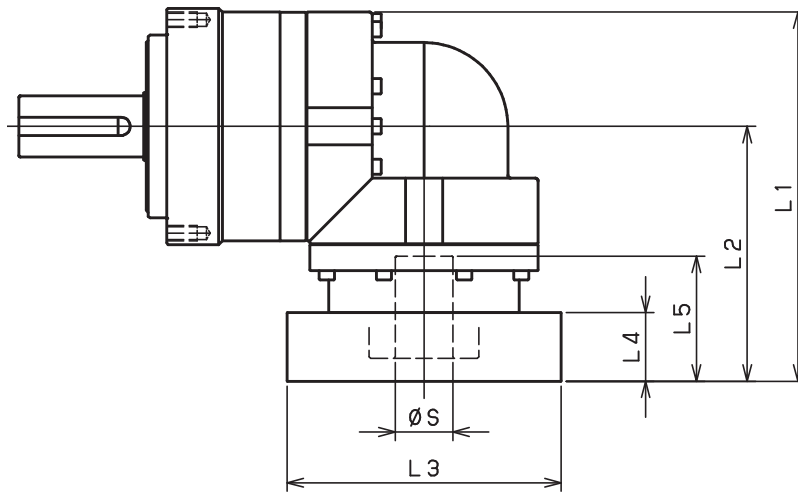

Model number	**: Adapter code	3-Stage				
		L1	L2	L3	L4	L5
EVL-235-□-□-38** (S ≤ 38)	HA	344	231.5	□130	45	82
	HB-HE	339	226.5	□130	40	77
	JA	344	231.5	□150	45	82
	KA-KB-KC	344	231.5	□180	45	82
	KD	379	266.5	□180	80	117
	KE	359	246.5	□180	60	97
	LA	344	231.5	□200	45	82
	LB	354	241.5	□200	55	92
	MA-MB	344	231.5	□220	45	82
	MC	359	246.5	□220	60	97
	MD	354	241.5	□220	55	92
	NA	344	231.5	□250	45	82
EVL-235-□-□-48** (38 < S ≤ 48)	KA	380.5	268	□180	75	118
	KB-KC	360.5	248	□180	55	98
	LA	360.5	248	□200	55	98
	MA	360.5	248	□220	55	98
	MB	380.5	268	□220	75	118
	NA	380.5	268	□250	75	118
	PA	380.5	268	□280	75	118
EVL-235-□-□-65** (48 < S ≤ 65)	MA-MB-MC-MD	--	--	--	--	--
	NA-NC	--	--	--	--	--
	NB-ND	--	--	--	--	--
	PA	--	--	--	--	--
	PB	--	--	--	--	--
	QA-QB	--	--	--	--	--

*1) Triple reduction : 1/15~ 1/100

*2) Bushing will be inserted to adapt to motor shaft

For an explanation on the Adapter Flange Code, please turn to page 422.

A more comprehensive adapter flange offering can be found using the NIDEC-SHIMPO Online Selector Tool. The variety is constantly expanding and being updated on the Selector Tool. If you have any questions or need any support, contact NIDEC-SHIMPO.